

University of Eastern Piedmont “Amedeo Avogadro”

*Department of Translational Medicine*



PhD thesis in Molecular Medicine

*XXVI cycle (2010-2013)*

**GENETIC VARIATIONS IN  
AUTOIMMUNE DEMYELINATING DISEASES  
OF THE NERVOUS SYSTEM**

**Dr. Sara Buttini**

*Tutor: Dr. Cristoforo Comi*

## INDEX OF CONTENTS

<b>SUMMARY</b> .....	3
<b>INTRODUCTION</b> .....	5
<b>Multiple Sclerosis:</b> a brief disease overview and insight into MS immunopathogenesis	
<b>Chronic inflammatory demyelinating polyneuropathy:</b> a picture of the disease and understanding of CIDP immunopathogenesis	
<b>SECTION 1: role of <i>UNC13D</i> gene in MS development</b> .....	14
<b>1.1</b> Background: <i>UNC13D</i> gene and its role in human diseases	
<b>1.2</b> Rationale for study and specific aims	
<b>1.3</b> Results and conclusions	
<b>Article 1:</b> <i>Variations of the <i>UNC13D</i> gene in patients with Autoimmune Lymphoproliferative Syndrome</i>	
<b>SECTION 2: role of osteopontin in MS development and progression</b> .....	26
<b>2.1</b> Background: OPN, role in immune regulation and association with MS	
<b>2.2</b> Rationale for study and specific aims	
<b>2.3</b> Results and conclusions	
<b>Article 2:</b> <i>The impact of osteopontin gene variations on Multiple Sclerosis development and progression</i>	
<b>SECTION 3: role of perforin gene in CIDP</b> .....	36
<b>3.1</b> Background: perforin and its role in human diseases	
<b>3.2</b> Rationale for study and specific aims	
<b>3.3</b> Materials and methods	
<b>3.4</b> Results and conclusions	
<b>SECTION 4: role of osteopontin in CIDP</b> .....	42
<b>4.1</b> Rationale for study and specific aims	
<b>4.2</b> Materials and methods	
<b>4.3</b> Preliminary results and conclusions	
<b>LIST OF PUBLICATIONS</b> .....	45
<b>REFERENCES</b> .....	46
<b>ABBREVIATIONS</b> .....	52
<b>ACKNOWLEDGEMENTS</b> .....	54

## SUMMARY

*Multiple sclerosis (MS) and chronic inflammatory demyelinating polyneuropathy (CIDP) are two inflammatory demyelinating nervous system disorders that share some similarities, including an autoimmune pathogenesis.*

*During the PhD program I investigated whether variations in genes that were previously associated to autoimmunity may contribute to MS and CIDP pathogenesis, focusing especially on three genes, UNC13D gene (that encodes for Munc13-4) and PRF1 (perforin) gene, that are important for immune regulation and surveillance, and SPP1 gene, that encodes for the inflammatory cytokine osteopontin (OPN). Munc13-4 and perforin proteins play a role in the cell-mediated cytotoxicity. Munc13-4, in particular, is involved in the granule exocytosis pathway, regulating the maturation of the secretory vesicles and in their priming before granule fusion with the plasma membrane, whereas perforin is stored in the lytic granules and forms pores in the target cell membrane, triggering the granzymes-mediated apoptosis. Mutations in PRF1 and UNC13D genes have been associated to familial haemophagocytic lymphohistiocytosis type 2 (FHL2) and type 3 (FHL3) respectively, an autosomal recessive disease due to defective function of cytotoxic cells.*

*OPN is involved in immune regulation by enhancing Th1 and Th17 responses. Increased OPN serum levels have been associated to several autoimmune diseases including MS and several studies have been demonstrated that OPN plays an important role in inducing disease relapses. Moreover, it has been previously reported that OPN gene variations at the 3' end of the gene are a predisposing factor for MS development and evolution.*

*This thesis reports the following findings:*

### **1. Role of UNC13D gene in MS development**

*The entire UNC13D coding region has been sequenced in 38 MS patients, 21 autoimmune lymphoproliferative syndrome (ALPS) patients and 20 Dianzani lymphoproliferative disease (DALD) patients compared to 61 healthy controls. It has been identified four rare missense variations in 3 heterozygous ALPS patients carrying p.Cys112Ser, p.Val781Ile and a haplotype comprising both p.Ile848Leu and p.Ala995Pro and it has been demonstrated that these loss of function variations are risk factors for ALPS development. Concerning MS, two frequent variations has been found, p.Ala59Thr and p.Arg928Cys, previously described in FHL patients. Their allelic frequencies are similar in patients and controls (p.Ala59Thr: MS 4%, ALPS 2,4%, DALD 2,5%, controls 4,1%; p.Arg928Cys: MS 2,6%, ALPS 2,4%, DALD 5%, controls 6,5%), suggesting that these variations are not involved in the development of MS.*

## **2. Role of osteopontin in MS development and progression**

By sequencing analysis, the +1239A>C SNP, located on 3' end of SPP1 gene, has been studied in 728 MS patients and 1218 healthy controls (a much larger cohort than the previous report), and the -156G>GG SNP, located in the 5' end of the gene, has been typed in the same patients and 912 controls. It has been found that only +1239A>C SNP show a statistically significant association with MS development, as the frequency of +1239A homozygotes are decreased in MS patients than controls (46% vs 52%,  $p=0,011$ ) and they display 1,27 lower risk of MS than +1239C carriers. Nevertheless, the analysis of -156G>GG SNP frequency have not revealed any significant difference between patients and controls. Intriguingly, both +1239A and -156GG SNPs influence MS progression, since patients homozygous for both alleles display slower progression of disability and slower switch from RR to SP courses than patients carrying +1239C and/or -156G and those homozygous for +1239A only. Moreover, patients homozygous for +1239A allele also display a significantly lower relapse rate than patients carrying +1239C, confirming the established role of OPN in MS relapses.

## **3. Role of perforin in CIDP**

By sequencing PRF1 gene in 94 CIDP patients and 158 age-matched controls it has been identified in both groups A91V variation, previously associated to FHL2, DALD and MS, and two missense variation (R4H and R385W) and a novel nonsense variation (Q423X) in CIDP patients. All together, carriers of these variation has been more frequent in patients than controls (21,3% vs 5,7%;  $p=0,0004$ ; OR=4,47). Although A91V has been the most frequent variations and has been displayed a trend of association with CIDP (19% vs 6%;  $p=0,0017$ ; OR=3,92), suggesting that A91V and possibly other perforin variations are susceptible factors for CIDP development.

## **4. Role of OPN in CIDP**

Preliminary results from ELISA assay performed on 44 CIDP patients and 22 healthy controls have been demonstrated that plasma OPN levels are significantly increased in patients than controls (mean value: CIDP patients 233,5 ng/mL vs controls 129,6 ng/mL;  $p=0,011$ ). By typing the +1239A>C SNP located on the 3' end of SPP1 gene in 64 CIDP patients, it has been found that the frequency of +1239A homozygotes are similar to those previously reported in MS patients (47% vs 46%), nevertheless further studies are needed to establish the role of OPN in CIDP development.

# **MULTIPLE SCLEROSIS**

## **A brief disease overview**

Multiple Sclerosis (SM) is a chronic autoimmune inflammatory disease of central nervous system (CNS) characterized by demyelination and axonal damage [1]. MS is among the most common causes of neurological disability in young adults, with more than 2 million people affected worldwide. Many epidemiological studies have been performed in Italy with an estimated prevalence of about 100 cases per 100,000. Incidence and prevalence rates varied across regions and the highest values have been found in Sicily and Sardinia [2]. The disease typically appears between 20 and 40 years of age, occasionally in childhood and late adulthood, and women are affected approximately twice as often as man [1].

The disease starts with variable symptoms that include weakness in one or more limbs, sensory disturbances, visual difficulties such as blurred vision and diplopia, gait instability and ataxia. Concurrently with disease worsening, most patients experience bladder dysfunction, fatigue and heat sensitivity. Other clinical features are Lhermitte's sign, an electrical sensation that runs down the spine and into the limbs followed by neck flexion, and Uhthoff's phenomenon, a worsening of symptoms when core body is exposed to higher temperature, such as after an exercise or an hot bath, both particularly characteristic of MS, as well as vertigo, tonic spasms and other paroxysmal symptoms. Cognitive impairment is also common, especially as the disease progresses, and includes memory loss, deficits in attention and problem-solving difficulties. Depression and unstable mood occur in the majority of patients [3].

Four clinical patterns of the disease are described:

- relapsing-remitting MS (RRMS),
- secondary progressive MS (SPMS),
- primary progressive MS (PPMS),
- progressive relapsing MS (PRMS).

RRSM is the most common form, manifested of about 85% of patients. It is characterized by acute symptomatic episodes of worsening (called relapses or exacerbations) that occurs in a period of time, followed by complete or partial recovery (remissions). Approximately in half of these patients SP course occurs within 10 years of disease onset and they experience a gradual progressive neurological decline with or without periods of remissions. PP form is more resistant to current treatments and affects about 10% of MS patients that display a steady worsening of

disability from onset. Finally, PRMS is a rare clinical pattern, affecting less than 5% of patients, and it is characterized by gradual progression of disability from disease onset, with relapses that appear later [3].

Several diagnostic criteria, continuously under revisions, have been proposed over the last decade to identify the disease [4]. Clinical evidence may be sufficient for a diagnosis, but possibly can be supported by other analysis. Magnetic resonance imaging (MRI), for instance, is useful for detecting the presence and the location of demyelinating areas (plaques) in CNS. More than 95% of patients display multiple asymmetrically lesions in the white matter, especially in the corpus callosum and in deep periventricular regions. Besides, by extrusion of the heavy metal gadolinium across the blood-brain barrier (BBB), new active lesions can be discovered, associated to breakdown of the BBB itself and perivenous inflammation. Advanced technologies can also be used to detect spinal cord lesions that are frequently present. Cerebrospinal fluid (CSF) studies, such as electrophoresis analysis, detect oligoclonal bands IgG-restricted in about 90% of MS patients that can provide evidence of chronic inflammation [3].

The disease evolves over several decades and death generally occurs 30 years of disease onset. On the average, life expectancy of MS patients is about 5-10 years lower than that of unaffected people. Nevertheless, two-thirds of the deaths are directly related to the consequences of the disease (such as increased risks and complications of infections) [1].

In the management of MS, there is no known cure for the disease and currently therapies aim to ameliorate its course, improving the quality of everyday life. Methylprednisolone or oral anti-inflammatory corticosteroids are used for the treatment of acute exacerbations that occur in RRSM, since they are effective in short-term treatments for reducing relapse duration and relieving symptoms. On the other hand, long-term therapies include disease-modifying treatments such as  $\beta$  interferons (IFNs), glatiramer acetate and Natalizumab (a monoclonal antibody against  $\alpha$ -4 integrin) that prevent relapse and slow down disease progression. Nonetheless, all these treatments fail to show a benefit in progressive forms of the disease. Other immunomodulatory agents are Mitoxantrone, approved for use in RRMS and SPMS as second-line agent, and Fingolimod, a sphingosine-1-phosphate receptor (S1PR) antagonist. Both treatments reduce the relapse rate and delay the progression of disability in patients with relapsing forms of the disease. Advances in understanding the disease stimulated the development of new therapeutic agents such as Rituximab, a chimeric monoclonal antibody targeting CD20+ B cells. Clinical trial studies have been demonstrated that this B-cells depleting strategy is effective in decreasing the number

of CNS lesions, as detected by MRI, and in reducing the relapse rate, but several agents have also reported promising results [5].

The etiology of MS is unknown. Several studies suggest that environmental triggers in a genetically susceptible individuals are involved in the pathogenesis of the disease, leading to an altered immune response directed against self that results in inflammation, demyelination and neurodegeneration. A large number of environmental factors have been investigated and include viral and bacterial infections, nutritional and dietary factors, pollution, solar radiation, temperature, chemical agents, and so on. Herpes virus simplex 1 or 2, cytomegalovirus, measles, mumps, rubella and Epstein-Barr virus have been promoted as the causative MS agents. Nevertheless, viral infection hypothesis account of several aspects related to geographical variation, CSF titer, viral reactivation and MS exacerbation. Instead, the genetic susceptibility in MS, that has been recently reviewed [6], has been initially suggested by familial aggregation and concordance twins studies [3]. However, the first genetic factor related to the disease has been the human leukocyte antigen (HLA) class II locus in the major histocompatibility complex (MHC) region, on chromosome 6p21, and the association with haplotype DRB1\*1501-DQA1\*0102-DQB1\*0602 has been confirmed during the last decades. Other non-HLA candidate genes have been identified by using Genome-Wide Association Studies (GWAS), highlighting an important role of immune system in the pathogenesis of the disease, and include cytokines (such as *IL7*, *IL12A*, *IL12B*) and cytokine receptors (*IL7R*, *IL2RA*, *IL22RA*), co-stimulatory molecules (*CD58*, *CD6*, *CD40*, *CD80*, *CD86*) and signal transducer molecules (*TYK2*, *STAT3*). In agreement, results from micro-RNAs (miRNAs) also underline the involvement of immune regulation in MS. Gene-expression studies performed on the CNS of both MS patients and experimental autoimmune encephalomyelitis (EAE) mice (MS animal model) provide valuable details on molecular pathways implicated in the disease and studies performed on peripheral blood show a central role for T cell activation and inflammation. In addition, it has been demonstrated that epigenetic factors, such as promoter methylation, regulates the expression of several genes, such as *PAD2*, *SHP-1* and *IL17A*. All those findings shed light on the etiology of the disease, underling the complexity of MS [6].

### **Insight into MS immunopathogenesis**

The hypothesis that MS is an autoimmune disease arises from several findings:

- the presence of inflammation at the site of lesions;
- the course of the disease could be modified by immunomodulatory agents;

- the presence of oligoclonal bands in CSF of patients;
- the disease susceptibility is associated to genes involved in the immune response [7].

In addition, the animal model shares some similarities with the human disease. In those mice, EAE is induced through immunization with myelin sheath proteins or peptides, such as proteolipid protein (PLP), myelin oligodendrocyte glycoprotein (MOG) or myelin basic protein (MBP), and the disease is also driven by myelin-specific CD4<sup>+</sup> T cells, that can be adoptively transferred to healthy animals. In these conditions, the mice develop a relapsing-remitting or a chronic progressive courses, characterized by CNS inflammation and demyelination, resembling MS [8]. Myelin-specific autoreactive T cells are also found in peripheral blood and CSF of MS patients, nevertheless the way in which these cells become activated in periphery still need to be elucidated. Molecular mimicry, whereas T cell activated against non-self epitopes from viral/bacterial agents cross-react with similar self-myelin epitopes, or myelin antigen constitutively exposure are some postulated mechanisms. After peripheral activation, autoreactive T cells transmigrate across the BBB in CNS, in a process involving adhesion molecules, chemokines and matrix metalloproteinases (MMPs) [7]. An important role is carry out by  $\alpha 4\beta 1$  integrin (VLA-4, very late activation antigen 4), expressed on the surface of activated lymphocytes, that interact with VCAM-1 (vascular cell adhesion molecule 1), expressed on endothelial cells of blood vessels [9]. The relevance of this interaction is suggested by the fact that Natalizumab, a humanized monoclonal antibody against  $\alpha$ -4 integrin subunit of VLA-4, used in the treatment of MS, inhibits the migration of autoreactive T cell into the CNS, reducing the disease activity [5]. MMPs are proteolytic enzymes implicated in BBB disruption through the degradation of the extracellular matrix and the basement membranes, but they also participate to demyelination, cytokines activation and axonal damage. Elevated peripheral blood and CSF levels of MMP-9 have been reported in MS patients and correlate with disease activity [10]. In the CNS, astrocytes, microglia and macrophages act as antigen presenting cells (APCs) and exhibit myelin antigens through class II MHC molecules to CD4<sup>+</sup> autoreactive T lymphocytes which are reactivated and are able to differentiate in various subtypes with different effector functions, such as lymphocyte T helper type 1 (Th1), secreting the pro-inflammatory cytokine interferon- $\gamma$  (IFN-  $\gamma$ ). MS is considered a primarily Th1-mediated disease [7]. Moreover several studies have been demonstrated that Th17, secreting IL-17, have a role in the pathogenesis of MS. In fact, increased expression of IL-17 have been found in peripheral blood, CSF and brain tissue of MS patients and the frequency of Th17 cells in CSF is significantly increased during exacerbations compared to remission phases of the disease [11]. In



addition, the phenotypic characterization of these cells reveals higher expression of activation markers and co-stimulatory and adhesion molecules than Th1 subset, highlighting their pathogenic role in MS [12]. In vitro studies have also demonstrated that Fingolimod, the S1PR modulator used in current MS therapies, suppress the generation of Th17 cells [5]. Regulatory T cells (Tregs) CD4+CD25+ may also be involved in MS. Their number in patients and healthy controls is similar, but patient Tregs have an impaired capacity to suppress the activation of myelin-specific T cells in the periphery, in particular in RRSM patients [13]. Furthermore several evidences suggest that CD8+ T cells (cytotoxic T lymphocytes, CTLs) take part in the disease process. In fact, these cells are present in the inflammatory infiltrate in CNS lesions and the adoptive transfer of activated myelin-specific CD8+ T cells induce EAE, prompting a role for CD8+ as effector cells in MS pathogenesis. Besides, axonal damage is correlated with the number of CD8+ T lymphocytes infiltrating MS lesions which attack directly neurons, probably through the releasing of soluble mediators. The involvement of the humoral immunity is suggested by the presence of oligoclonal immunoglobulins in CSF of patients. B cells may directly contribute to demyelination by secreting antibody that target oligodendrocytes (with or without complement) [7]. In addition, Rituximab therapy, an anti-CD20 monoclonal antibody which efficiently depletes B cells, reduce MS inflammatory brain lesions and clinical relapses [5].

Demyelination is considered a primary pathological feature of MS, while axonal loss is an important pathological finding that correlate with disease progression and permanent neurological disability in patients. Mechanisms for axonal damage in MS are several and can include an immunological attack on axons, soluble mediators such as proteases, cytokines, and free radicals released in the inflammatory environment or in CSF of MS patients, or lack of axonal neurotrophic factors provided by oligodendrocytes as a result of chronic demyelination [7].

## **CHRONIC INFLAMMATORY DEMYELINATING POLYNEUROPATHY**

### **A picture of the disease**

Chronic inflammatory demyelinating polyneuropathy (CIDP) is a rare autoimmune disorder of the peripheral nervous system (PNS). The disease can occur at any age, but it mainly affect young adults, especially men. Clinical features, age of onset and the course of the disease vary among patients. Because of the heterogeneity of clinical presentations and the absence of specific markers for definite diagnosis, CIDP is often misdiagnosed and probably underestimated. In the epidemiological studies performed to date, the prevalence ranges from 1 to 7,7 per 100,000 [14]. A Northern Italy study reported a prevalence of 3,58 per 100,000 [15].

CIDP is clinically characterized by symmetrical proximal and distal weakness, associated to altered sensation, absence or diminished tendon reflexes (areflexia or hyporeflexia), elevated protein levels in CSF and heterogeneous slowing of nerve conduction, due to demyelination. CIDP is typically a slowly progressive disease that evolves over more than 2 month, distinguishing from Guillain-Barré syndrome (GBS), which has an acute onset.

Three types of clinical patterns of the disease have been described:

- a monophasic course, characterized by the progression of the disease until fully recovery with treatment, usually in absence of relapse;
- a relapsing-remitting course, in which period of relapses are followed by complete remissions;
- a chronic progressive course, in which patients display a progressive deterioration.

About 20-35% of patients show a relapsing-remitting form, while about 7-50% of patients present a monophasic disease.

CIDP selectively involves the peripheral system, both motor and sensory fibres (although in some cases motor or sensory fibres are affected). Moreover the disease is characterized by a progressive worsening or fluctuating course. Occasionally, cranial nerves are affected. CIDP can also be associated with various conditions, including hepatitis C, inflammatory bowel disease, lymphoma, monoclonal gammopathy of undetermined significance (MGUS), acquired immune deficiency syndrome (AIDS), organ transplant and connective tissue disorders. Furthermore, several studies have been reported that CIDP is more frequent in patients with diabetes mellitus than in general populations, but other investigations are controversial. CIDP is also been reported in patients with

Charcot-Marie-Toth disease, suggesting that different inflammatory mechanisms might occur in hereditary neuropathies and contribute to disability.

CIDP may also appear in childhood and it is characterized by a rapid onset, greater disability at the peak of the disease and a relapsing course in comparison with adult patients, but it responds better to treatment, with a more favourable long-term outcome [16].

In general, diagnosis is primary based on a neurological examination, that assess the presence of clinical features, and on electrophysiological studies, that often show a slowing or blocking of nerve conduction due to demyelination. Further laboratory investigations can be required and include CSF investigations, that reveal an increased protein levels and a normal or slightly elevated cell count, and nerve biopsy, usually of the sural nerve, histological evidence of demyelination and remyelination, often associated to inflammatory infiltrates.

Therapies are addressed to block the immune processes, aiming to arrest inflammation and demyelination, and to prevent secondary axonal degeneration, that leads to permanent disability [17]. The most widely used treatments are intravenous immunoglobulins (IVIgs) and corticosteroids, that are effectively, while plasma exchange can be used as rescue therapy. Several studies have also been performed to evaluate the beneficial use of immunosuppressant agents in the treatment of CIDP.

Long-term prognosis is dependent on the age of onset, clinical course of the disease and initial response to treatment. Young patients with a rapid onset or a monophasic course are more likely to respond to treatment and recover completely, while in elderly patients (more than 60 years) the frequency of fully recovery after treatment is less that younger ones. Moreover proximal weakness has been linked to a higher remission rate and better prognosis compared to clinical patterns with distal weakness. In addition, progressive course and axonal degeneration are the main negative prognostic factors of CIDP, meaning that patients with monophasic or relapsing-remitting courses have a better prognosis than other patients [16].

Few studies have been performed on genetics of CIDP, nevertheless a strong association with a specific gene have not yet been demonstrated. In agreement with that, several works reported polymorphisms in the HLA region, but they failed to detect a well-defined associations, due to the small number of patients and because of the heterogeneity of CIDP [18-21]. Another study suggest a gender-specific association of DR2 alleles in female patients [22] and recently Mrad et al., by analyzing HLA-DR/DQ allele in a Tunisian population, have been found an association with the HLA-DRB1\*13 allele [23]. Despite these findings, a significant association has been identified in a

homozygous genotype for a low repeat number of tandem GA in the *SH2D2A* gene, encoding for a T-cell-specific adapter protein (TSAD) [24]. Furthermore, two controversial studies have been reported that a SNP in the transient axonal glycoprotein-1 (TAG-1) gene is associated with IVIg responsiveness in Japanese CIDP patients [25], by contrast no association has been found in Chinese patients [26].

## **Understanding of CIDP immunopathogenesis**

Several evidences support that CIDP is an autoimmune disease:

- presence of inflammation in the site of lesions;
- response to immunomodulatory treatments;
- presence of autoantibodies against myelin antigens.

In the pathogenesis of the disease both humoral and cell-mediated immune response are directed against peripheral nerve antigens, leading to demyelination and secondary to axonal loss, the major feature causing the neurological disability. Although many efforts carried out in this way, the target antigen of the immune attack has not yet been identified. In animal models, experimental autoimmune neuritis (EAN) can be induced by immunisation with peripheral nerve myelin or myelin proteins with Freund's adjuvant. A similar disease can be induced also in Lewis rats with purified myelin protein (P2), myelin protein zero (P0) and peripheral myelin protein 22 (PMP22), candidate autoantigens in CIDP [27]. Immunohistochemical studies from nerve biopsy specimens of CIDP patients show an increased number of T cell with  $\gamma\delta$ -receptors, suggesting a T cell response against a non-protein antigen, such as gangliosides [28].

Several evidences from human patients and animal model studies identify the presence of T lymphocytes, belonging to both CD4+ and CD8+ subsets, demonstrating that CIDP is a predominantly T driven disease [17]. Moreover, increased serum levels of tumor necrosis factor- $\alpha$  (TNF- $\alpha$ ) and IL-2 have been found in patients, suggesting T cell activation [16]. Activated T cells cross the blood-nerve barrier (BNB) to reach PNS, in a process that involves homing, adhesions and transmigration. An increase in adhesion molecules, MMPs (especially MMP-9 and MMP-2) and chemokines has been found in CSF, serum and nerves of CIDP patients [16, 27]. In addition, the tight-junction proteins, claudin-5 and ZO-1 (zona occludens protein 1) are down-regulated in sural nerve biopsy specimens, demonstrating a damage to BNB [29]. Following transmigration, T cells are reactivated inside the endoneurium, as suggested by Schwann cell expression of CD58, the adhesion and T cell stimulatory molecule, found in nerve samples from CIDP patients [30].

Furthermore, Comi et al. have demonstrated that T cell apoptosis is impaired in CIDP patients, which T cells display lower Fas function, a death receptor expressed on activated lymphocytes that is involved in switching-off the immune response, compared to both healthy controls and GBS patients [31]. Besides, T cell suppression is also defective, as CIDP patients show a significant reduction in both number and suppressive function of Tregs compared to healthy controls [32].

Several co-stimulatory molecules implicated in T cell activation, such as B7-1 (CD80) [33] and BB-1 [34], has been found up-regulated in biopsy sample from patients, suggesting a potential role in the disease. In addition, non-obese diabetic (NOD) mice, deficient in B7-2 (CD86) co-stimulation, develop a spontaneous autoimmune peripheral polyneuropathy, which has many similarities with the human disease [35]. The inducible co-stimulatory molecule (ICOS), expressed by T cells, and its ligand (ICOS-L), localized on macrophages, have been identified in nerves from CIDP and GBS patients [36]. Macrophages have a double role in the pathogenesis of CIDP: from one side they act as antigen presenting cells that sustain the immune response, on the other hand they actively cause demyelination, probably enhancing their phagocytic and cytotoxic activity, with the production of pro-inflammatory cytokines and the release of toxic mediators such as oxygen radicals, nitric oxide metabolites, arachidonic acid metabolites, proteases and complement components [17]. In fact, macrophages, that invade the endoneurium, express pro-inflammatory cytokines and cyclo-oxygenase 2 [37].

Despite the role of autoantibodies in the pathogenesis of CIDP has been suggested since more than 20 years ago, antibodies against component of peripheral nerve myelin or neuronal antigen have been inconsistently found in patients [27]. Experimental animal studies has been demonstrated that the intraneural injection of serum or purified IgG from patients induce conduction block and demyelination in rat nerves. In these studies, P0 has been identified as one of the putative antigen and autoantibodies against these proteins are also detected in some CIDP patients [38]. In agreement with this, in another murine model the adoptive transfer of P0-reactive T cells are able to induce the neuropathy [39]. Moreover, in another study P2 seem to be the most likely candidate [40]. The effectiveness of plasma exchange in the treatment of CIDP support the role of humoral factors, but improvement may additionally bring on the elimination of inflammatory mediators that contribute to demyelination and subsequently axonal loss [16].

## SECTION 1

### Role of *UNC13D* gene in MS development

#### 1.1 Background: *UNC13D* gene and role in human diseases

The human *UNC13D* gene (*unc13* homolog D, referred to *C. Elegans* gene) is located on chromosome 17q25 and consists of 32 exons encoding for Munc13-4, a protein of 1090 amino acids. Munc13-4 is a member of Munc13 family of proteins involved in vesicle priming function that include four homologous isoforms. Munc13-2 is ubiquitously expressed, while Munc13-1 and Munc13-3 are mainly present in the brain. Munc13-4 is the isoform lastly discovered and is highly expressed in hematopoietic cells, such as CTLs, natural killer (NK) cells and platelets. Munc13-4 exhibit the typical Munc13 domain structure with two Munc13 homology domain (MHDs), involved in the protein localisation, two C2 domains, known to bind calcium and phospholipids, but lack the N-terminal phorbol ester-binding C1 domain, present in other Munc13 proteins [41-42]. It participates in the cytotoxic granule exocytosis, important in the perforin-dependent pathway for the cytotoxic function of CTLs and NK cells, that play a crucial role in both immune surveillance and immune regulation (together with death receptor-dependent pathway). This process involves the formation of granules, their fusion with the plasma membrane and the release of their contents (perforin and granzymes) through the immunological synapse on target cells that undertake the apoptotic cell death. In particular, Munc13-4 is involved in the cytolytic granule maturation, mediating the association of recycling endosomes (through Rab11) with late endosomes (through Rab7) that form exocytic vesicles, carrying effector proteins of the exocytic machinery, such as Munc13-4, Rab27a and SLP2 (synaptotagmin-like protein). Following target cell recognition, these vesicles coalesce with perforin-containing granules and are tethered to the plasma membrane. Moreover Munc13-4 also mediates a priming step that is required to enable fusion of the cytotoxic granules with the plasma membrane: Munc13-4 probably triggers the conformational change of the docking complex Syntaxin11/Munc18-2 in the active form, regulating the interaction between SNARE proteins (N-ethylmaleimide-sensitive factor attachment protein receptors) expressed on the vesicle membrane (v-SNARE) and on target membrane (t-SNARE) important for the fusion step [43].

Mutations of *UNC13D* gene are responsible for approximately 40% of cases of familial haemophagocytic lymphohistiocytosis type 3 (FHL3) [42], an autosomal recessive disease affecting

infants and young children. Mutations in other genes involved in the exocytosis of cytotoxic granules pathway are also identified in patients affected by FHL and include loss-of-function mutations in the perforin (*PRF1*) gene (FHL2), syntaxin-11 (*STX11*) gene (FHL4) and Munc18-2 (*STXBP2*) gene (FHL5). The clinical features of the disease include fever, splenomegaly, hepatomegaly, anemia, thrombocytopenia and neutropenia. NK and CTL cytotoxicity are severely impaired. Moreover, the disease is also characterized by an uncontrolled immune response that results in infiltration and destruction of tissues by activating macrophages (CD68+) and CD8+ T cells, followed by the release of pro-inflammatory cytokines. Activated macrophages and T cells are often present in the bone marrow, spleen, lymph node, liver and CNS, however other organs may also be infiltrated [44]. Patients carried *UNC13D* mutations show a correct docking of cytotoxic granules at the site of secretion, but these vesicles cannot fuse with the plasma membrane and are not able to secrete their content, leading to a defective cytotoxic activity [42, 44].

## 1.2 Rationale for the study and specific aims

Several findings suggest that death receptor- and perforin- dependent pathways are fundamental for immune surveillance and regulation and that absent or decreased function of proteins involved in these pathways predisposes to autoimmunity.

FHL is a lymphoproliferative disorder in which a role of both *PRF1* and *UNC13D* gene mutations has been demonstrated. Mutations in *PRF1* gene, encoding for perforin, a molecule stored in the cytotoxic granules, lead to FHL2, while mutations in *UNC13D* gene, encoding for Munc13-4, a protein responsible for the priming of the cytotoxic vesicles before their fusion with the plasma membrane, are found in patients with FHL3 [44].

Autoimmune lymphoproliferative syndrome (ALPS) is an inherited autoimmune disease caused by mutations of several genes involved in the Fas death receptor-dependent pathway [45]. The disease is characterized by defective Fas function, accumulation of non malignant lymphocytes in the lymphoid organ with lymphadenopathy/splenomegaly, autoimmune manifestation and expansion of CD4/CD8 double negative (DN) T cells [46]. In most ALPS patients (ALPS-FAS) are found mutations in the Fas gene (*FAS*), but a small number of patients (ALPS-FASL and ALPS-CASP10) carried mutations of Fas ligand (*FASL*) or caspase-10 (*CASP10*), downstream effectors in the Fas/FasL pathway. Moreover, in a substantial proportion of patients (ALPS-U) the mutated gene is unknown, but it may be another downstream component of the pathway. It is also been described an incomplete form of ALPS showing defective Fas function, autoimmunity and

lymphoproliferation, but lacking of DN T cell expansion that has been named Dianzani lymphoproliferative disease (DALD) [47].

Variations in *PRF1* gene are associated to ALPS/DALD in subject with defective Fas function [48]. In addition, concerning *UNC13D* gene, we have identified four rare missense variations in 3 heterozygous ALPS patients carrying p.Cys112Ser, p.Val781Ile and a haplotype comprising both p.Ile848Leu and p.Ala995Pro and we have demonstrated that these loss of function variations are risk factors for ALPS development [**Article 1**].

Defective Fas function are also been found in MS: Fas-induced cell death is significantly lower in patients than controls and the Fas defect is more frequent in patients with progressive forms of the disease, suggesting that it may favour the progression of MS [49]. Furthermore, perforin gene variations have been associated to MS: two FHL2-associated variations (A91V and N252S) and other six novel mutations (C999T, G1065A, G1428A, A1620G, G719A, C1069T) were found in MS patients. Such variations collectively confer susceptibility for the disease [50]. These results highlight that MS (similarly to ALPS) shows defective Fas function and variations of perforin gene that are involved in the down-modulation of immune response thus predisposing to autoimmunity.

On the basis of these findings, the aim of this study was to assess the role of *UNC13D*, another gene involved in perforin-dependent pathway, in the development of MS.

### 1.3 Results and conclusions

As reported in the following article, the entire *UNC13D* coding region has been sequenced in 38 MS patients and has been compared to 61 healthy controls, 21 ALPS and 20 DALD patients. Two frequent variations has been found in MS patients: p.Ala59Thr (c.175G>A; rs9904366) and p.Arg928Cys (c.2782C>T; rs35037984), previously described in FHL patients. The first variation p.Ala59Thr is carried by 3 MS patients and 5 healthy controls, but it is also identified in 1 ALPS and 1 DALD patient. The second variations p.Arg928Cys is carried by 2 MS patients, 8 healthy controls, 1 ALPS and 2 DALD patients. These variations have been detected in all patients and controls with similar allelic frequencies (p.Ala59Thr: MS 4%, ALPS 2,4%, DALD 2,5%, healthy controls 4,1%; p.Arg928Cys: MS 2,6%, ALPS 2,4%, DALD 5%, healthy controls 6,5%,) demonstrating that they are not a risk factor for MS development.



## ARTICLE 1

OPEN ACCESS Freely available online

PLOS ONE

## Variations of the *UNC13D* Gene in Patients with Autoimmune Lymphoproliferative Syndrome

Maurizio Aricò<sup>1</sup>, Elena Boggio<sup>2,3</sup>, Valentina Cetica<sup>1</sup>, Matteo Melensi<sup>2,3</sup>, Elisabetta Orilieri<sup>2,3</sup>, Nausicaa Clemente<sup>2,3</sup>, Giuseppe Cappellano<sup>2,3</sup>, Sara Buttini<sup>2,4</sup>, Maria Felicia Soluri<sup>2,3</sup>, Cristoforo Comi<sup>2,4</sup>, Carlo Dufour<sup>5</sup>, Daniela Pende<sup>6</sup>, Irma Dianzani<sup>2,3</sup>, Steven R. Ellis<sup>7</sup>, Sara Pagliano<sup>8</sup>, Stefania Marcenaro<sup>5</sup>, Ugo Ramenghi<sup>8</sup>, Annalisa Chiocchetti<sup>2,3\*</sup>, Umberto Dianzani<sup>2,3</sup>

**1** Department of Pediatric Hematology Oncology, Meyer Children Hospital, Firenze, Italy, **2** Interdisciplinary Research Center of Autoimmune Diseases (IRCAD), "A. Avogadro" University of Eastern Piedmont, Novara, Italy, **3** Department of Health Sciences, "A. Avogadro" University of Eastern Piedmont, Novara, Italy, **4** Department of Translational Medicine, "A. Avogadro" University of Eastern Piedmont, Novara, Italy, **5** Istituto Giannina Gaslini, Genova, Italy, **6** IRCCS AOU San Martino-IST, Genova, Italy, **7** Department of Biochemistry and Molecular Biology, University of Louisville, Louisville, Kentucky, United States of America, **8** Department of Pediatrics, University of Torino, Torino, Italy

### Abstract

Autoimmune lymphoproliferative syndrome (ALPS) is caused by genetic defects decreasing Fas function and is characterized by lymphadenopathy/splenomegaly and expansion of CD4/CD8 double-negative T cells. This latter expansion is absent in the ALPS variant named Dianzani Autoimmune/lymphoproliferative Disease (DALD). In addition to the causative mutations, the genetic background influences ALPS and DALD development. We previously suggested a disease-modifying role for the perforin gene involved in familial hemophagocytic lymphohistiocytosis (FHL). The *UNC13D* gene codes for Munc13-4, which is involved in perforin secretion and FHL development, and thus, another candidate for a disease-modifying role in ALPS and DALD. In this work, we sequenced *UNC13D* in 21 ALPS and 20 DALD patients and compared these results with sequences obtained from 61 healthy subjects and 38 multiple sclerosis (MS) patients. We detected four rare missense variations in three heterozygous ALPS patients carrying p.Cys112Ser, p.Val781Ile, and a haplotype comprising both p.Ile848Leu and p.Ala995Pro. Transfection of the mutant cDNAs into HMC-1 cells showed that they decreased granule exocytosis, compared to the wild-type construct. An additional rare missense variation, p.Pro271Ser, was detected in a healthy subject, but this variation did not decrease Munc13-4 function. These data suggest that rare loss-of-function variations of *UNC13D* are risk factors for ALPS development.

**Citation:** Aricò M, Boggio E, Cetica V, Melensi M, Orilieri E, et al. (2013) Variations of the *UNC13D* Gene in Patients with Autoimmune Lymphoproliferative Syndrome. PLoS ONE 8(7): e68045. doi:10.1371/journal.pone.0068045

**Editor:** Graham R. Wallace, University of Birmingham, United Kingdom

**Received:** January 3, 2013; **Accepted:** May 24, 2013; **Published:** July 1, 2013

**Copyright:** © 2013 Aricò et al. This is an open-access article distributed under the terms of the Creative Commons Attribution License, which permits unrestricted use, distribution, and reproduction in any medium, provided the original author and source are credited.

**Funding:** This work was partly supported by Antonio Pinzino - Associazione per la Ricerca sulle Sindromi Emofagocitiche - ARSE (Palermo), Italian Ministry of Health Progetti di ricerca finalizzata 2008, Bando "Malattie Rare 2008" RF-TOS-2008-1219488 (Rome), Fondazione Cariplo Ricerca (Milan), Fondazione Amici di Jean (Turin), FISM 2011-R (Genoa), Fondazione Cassa di Risparmio di Cuneo (Cuneo), AIRC (Milan), Regione Piemonte (Piattaforme Innovative Project) (Turin), and PRIN-MIUR project (Rome). The funders had no role in study design, data collection and analysis, decision to publish, or preparation of the manuscript.

**Competing interests:** The authors have declared that no competing interests exist.

\* E-mail: annalisa.chiocchetti@med.unipmn.it

### Introduction

The lytic granules of cytotoxic T cells (CTL) and natural killer (NK) cells contain perforin and granzymes, which are released on the target cell surface and induce its death [1]. The exocytosis mechanism of the lytic granules is not fully understood, but it involves machinery composed of several proteins including Munc13-4, Munc18-2, and syntaxin11 [2]. Deficiencies of perforin function are responsible for familial hemophagocytic lymphohistiocytosis (FHL), an autosomal recessive disease characterized by bouts of prolonged fever,

hepatosplenomegaly, and cytopenia due to defective function of CTL and NK cells. FHL has been ascribed to defective clearance of virus-infected cells leading to cytokine and effector cell overproduction with massive tissue damage [3]. Approximately 40% of FHL cases (FHL2) are due to mutations of the perforin gene (*PRF1*), with another 40% (FHL3) due to mutations of the Munc13-4 gene (*UNC13D*). Moreover, a small number of patients with FHL have been found to harbor mutations of *STX11*, encoding Syntaxin-11 (FHL4), or *STXBP2*, encoding Munc18-2 (FHL5) [4].

Autoimmune lymphoproliferative syndrome (ALPS) is another genetic lymphoproliferative disease and is characterized by lymphadenomegaly and/or splenomegaly, due to polyclonal accumulation of lymphocytes, and peripheral expansion of CD4/CD8 double-negative (DN) T cells [5–10]. In addition, patients often display autoimmune manifestations that predominantly involve blood cells and are predisposed to lymphomas in adulthood [11]. ALPS is due to defective function of the Fas/Apo-1 (CD95) death receptor, inducing apoptosis of the Fas-expressing cell upon binding with Fas ligand (FasL) [12,13]. Activated lymphocytes express Fas and the Fas/FasL interaction is involved in shutting off immune responses, lymphocyte lifespan regulation, and maintenance of peripheral tolerance [14,15]. Moreover, the Fas pathway is an additional weapon, reinforcing the perforin system in the cytotoxicity mediated by CTL and NK cells because these cells express FasL and induce apoptosis of target cells expressing Fas. In most patients (ALPS-FAS), ALPS is due to mutations of the Fas gene (*FAS*), but a small number of patients (ALPS-FASL and ALPS-CASP10) carry mutations in the genes encoding FasL (*FASL*) or caspase-10 (*CASP10*), a downstream effector in the Fas/FasL pathway. As a substantial proportion of ALPS patients (ALPS-U) lack mutations in *FAS*, *FASL*, and *CASP10*; it seems likely that mutations in unknown genes encoding other downstream components of the Fas cell death pathway may give rise to the additional ALPS cases [9,10]. We have also described an incomplete form of ALPS showing defective Fas function, autoimmunity, and lymphoproliferation, but lacking the expansion of DN T cells. This variant form has been named Dianzani Autoimmune Lymphoproliferative Disease (DALD) by Victor McKusick (OMIM # 605233) [10,16–18]. Patients with DALD did not display mutations in *FAS*, *FASL*, or *CASP10*, but most of the parents displayed a defect in the Fas pathway. These data suggest that mutations in genes encoding downstream effectors of the Fas pathway may also give rise to DALD.

In addition to the Fas defect, the clinical presentation of ALPS also appears to be influenced by modifier genes. In mice, a disease displaying features of ALPS has been reported for MRL *lpr/lpr* and *gld/gld* mice, carrying mutations of *FAS* and *FASL*, respectively. Disease presentation in these mice is dramatically affected by strain background, with strains other than MRL showing much milder phenotypes when homozygous for either *lpr* or *gld* mutations [12,19]. Similar background effects likely explain the incomplete penetrance of ALPS mutations in humans [20]. Most ALPS patients are heterozygous for the *FAS* mutation, but parents carrying the same mutation are generally healthy. The same observation is true in DALD, where parents typically display defective Fas function, but are otherwise healthy [17,18]. This observation indicates that mutations in genes of the Fas pathway may be necessary but not sufficient for ALPS development and variations in one or more additional genes may influence disease presentation [9].

In previous works, we correlated certain variants of the perforin gene (*PRF1*) with ALPS/DALD development and suggested that mild heterozygous variations of *PRF1* incapable of inducing FHL may act as susceptibility genes for ALPS/

DALD development in subjects displaying defective Fas function [21,22]. The aim of this work was to extend this observation to the *UNC13D* gene, looking for variations in ALPS and DALD patients and assessing its potential role as a disease-modifier gene. We found that loss-of-function variations of *UNC13D* are relatively frequent in patients with ALPS, suggesting that it may influence the presentation of this lymphoproliferative disorder.

## Materials and Methods

### Patients

We analyzed 41 unrelated Italian patients, 21 with ALPS and 20 with DALD. All patients were diagnosed at the Pediatric Department of the University of Turin using criteria established at the 2009 ALPS NIH International Workshop [10]. *FAS* (NCBI ID: 355) and *CASP10* (ID: 843) were sequenced in all patients as reported previously [16,17]. Among the ALPS patients, 7 carried heterozygous mutations of *FAS* (ALPS-FAS), 14 did not carry any known mutation (ALPS-U). None of the patients fulfilled the diagnostic criteria for FHL. A total of 61 healthy individuals were used as controls for *UNC13D* sequencing, and a second cohort of 100 healthy controls were used to genotype the rare variations. Moreover, *UNC13D* was sequenced in 38 patients with Multiple Sclerosis (MS) from the MS Center of the "Amedeo Avogadro" University of Eastern Piedmont (Novara). The study was planned according to the guidelines of the local ethical committee, Azienda Ospedaliera della Carità, of Novara that approved the study (Protocol 106/CE). For the patients followed at Paediatric Department of the University of Torino, a written informed consent was signed by the patients, or by the parents if they were minors.

### Fas function assay

Fas-induced cell death was evaluated on T cells obtained by activating peripheral blood mononuclear cells (PBMC) with phytohemagglutinin (Sigma, St Louis, MO, Canada) at days 0 (1 µg/mL) and 12 (0.1 µg/mL) and cultured in RPMI 1640 plus 10% fetal calf serum and recombinant IL-2 (rIL-2, 2 U/mL) (Sigma). Fas function was assessed 6 days after the second stimulation (day 21). Cells were incubated with control medium or anti-Fas monoclonal antibody (mAb) (CH 11, 1 µg/mL) (Millipore, Billerica, MA) in the presence of rIL-2 (1 U/mL) to minimize spontaneous cell death. Cell survival was evaluated after 18 hours by counting live cells by the trypan blue exclusion test. Assays were performed in duplicate. Cells from 2 healthy donors were included in each experiment as positive controls. The results were expressed as percent specific cell-survival, calculated as follows: (total live-cell count in the assay well/total live-cell count in the control well) X100%. Fas function was defined as defective when cell survival was less than 82% (the 95<sup>th</sup> percentile of data obtained from 200 healthy controls) [17,18].

### UNC13D sequencing

Genomic DNA was isolated from peripheral blood samples using a BioRobot® EZ1 Workstation (Qiagen, Jesi, Italy).

Exons and intron-exon boundaries of *UNC13D* (ID: 201294), were amplified and directly sequenced in both directions with the BigDye® Terminator Cycle Sequencing Ready Reaction Kit (Applied Biosystems, Foster City, CA, USA). Primers are available upon request. Sequences were analyzed and compared with the reported gene structure. The missense variations identified in patients were also assessed in parents.

Allele expression was evaluated in total RNA extracted from PBMC of heterozygous donors. RNA was reverse transcribed into cDNA with the ThermoScript™ RT PCR System (Invitrogen, Burlington, ON, Canada) and the exons containing the *UNC13D* variations were amplified. PCR products were subcloned into the pGEM-T vector (Promega Corporation, Madison, WI, USA) and transformed into TOP10 *E. coli* competent cells (Invitrogen). In each selected patient, we screened 30 independent colonies; plasmid DNA was extracted with a QIAPrep Spin miniprep Kit (QIAGEN GmbH, Hilden, Germany) and sequenced.

#### Functional analysis of the variations

Munc13-4 cDNA (ImaGenes, BioDiscovery, Inc. Suite CA, USA) was subcloned into the pcDNA 3.1 expression vector (Invitrogen), and the Sv5 tag was added at the 5' end by PCR. The mutants were created in the Munc13-4 wild-type construct by PCR and then transfected into the HMC-1 human mast cell line, originally established from the peripheral blood of a patient with mast cell leukemia [23] and kindly provided by C. Dianzani. Cells were transfected by Amaxa Cell Line Nucleofactor Kit V (Lonza, Basel, Switzerland), according to the manufacturer's instructions. Briefly, 4 µg of each construct were co-transfected with 1 µg of the pEGFP vector (Invitrogen). Transfection efficiency was analyzed by cytofluorimetric evaluation, and determined by calculating the % of GFP expressing cells. To investigate Munc13-4 expression levels, cells were lysed and proteins resolved by gel electrophoresis were analyzed using mAb to Sv5 and actin (Santa Cruz Biotechnology, Inc. Santa Cruz, CA, USA). Immunoreactive proteins were visualized with HRP-conjugated goat anti-mouse IgG (Sigma).

To investigate primary granule exocytosis, transfected HMC-1 cells ( $1 \times 10^6$ /ml) were incubated in Tyrod Buffer (Hepes 10 mM pH=7.4, NaCl 173 mM, KCl 2.9 mM, NaHCO<sub>3</sub> 12 mM with 1.6 mM CaCl<sub>2</sub> and 5 mM Glucose) and stimulated with 10<sup>-6</sup> M formyl-methionyl-leucyl-phenylalanine peptide (fMLP, Sigma) at 37°C for 10 min. Exocytosis was then assessed on the GFP-expressing cells by cytofluorimetric analysis of CD63 expression, using the mean fluorescence intensity ratio between stimulated and unstimulated cells set at 100% [24].

The functional effects of the *FAS* mutations were assessed by transfecting the mutated cDNA, subcloned into pcDNA3.1 (Invitrogen) in 293T cells. Wild-type cDNA of *FAS* bearing the FLAG tag at the 5'-end was a kind gift of Giovina Ruberti (National Research Council, CNR, Rome). The p.Gln273His and p.Glu261Lys mutants were created in the *FAS* construct by PCR. Cells were transfected and lysed as for Munc13-4 and immunoblotted with anti-FLAG mAb (Sigma).

#### Analysis of caspase-8 activity

Caspase-8 activity was evaluated, as previously reported [25], in 100 µg of cell lysates obtained from Fas-transfected 293T cells ( $5 \times 10^6$ ), 24 hours after transfection, using a fluorimetric assay according to the manufacturer's instructions (MBL, Watertown, MA). The results were expressed as relative caspase-8 activity (in %), which was calculated as (activity of Fas transfected cells/activity of mock transfected cells) X100%.

#### Functional analyses of patient NK cells

PBMC were cultured overnight at 37°C in 5% CO<sub>2</sub> in media with or without rIL-2 (600 U/ml) (Proleukin, Chiron Corp., Emeryville, USA) to test degranulation of resting and activated NK cells, respectively. PBMC derived from patients' relatives and/or unrelated healthy donors were tested in parallel. Surface expression of CD107a was assessed on CD3<sup>+</sup>CD56<sup>+</sup> cells upon co-incubation of PBMC with K562 cells in the presence of Phycoerythrin-conjugated anti-CD107a mAb for 2 hours at 37°C, as previously described [26,27]. Thereafter, cells were stained with APC-conjugated anti-CD56 and PerCP-conjugated anti-CD3 mAb, and analyzed by flow cytometry (FACSCalibur, Becton Dickinson Biosciences, CA, USA). The results were considered by assessing the change in % CD107a (i.e., % CD107a<sup>+</sup> cells in stimulated samples – % CD107a<sup>+</sup> cells in unstimulated samples). All reagents were from BD Biosciences. NK cells were also purified using the RosetteSep method (StemCell Technologies, Vancouver, British Columbia, Canada), following manufacturer's instructions, and cultured in appropriate conditions to obtain high numbers of polyclonal activated NK cells [26]. To analyze the cytolytic activity in 4 hour <sup>51</sup>Cr-release assays, PBMC were tested against K562 cells, while activated NK cells were tested against the HLA-class I-negative B-EBV cell line 721.221, as previously described; lytic units were calculated at 30% lysis [26,27].

#### Statistical analysis

Statistical analysis was performed using the ANOVA followed by Dunnett's multiple comparison test; \*p<0.05, \*\*p<0.01. The results are shown as the mean and standard error (SE). Genotype distributions were analyzed with the Fisher's exact test. All *P*-values are 2-tailed, and the significance cut-off was p<0.05.

#### Results

##### Genetic analyses

The coding sequences (exons and intron boundaries) of *UNC13D* were sequenced in 21 patients with ALPS (ALPS-FAS: N=7; ALPS-U: N = 14) and 20 with DALD. We identified 6 heterozygous missense variations in *UNC13D* in 8 patients (2 ALPS-FAS, 3 ALPS-U, 3 DALD). The variations and their inheritance are described in Table 1 and Figure 1.

Two variations had been previously described in patients with FHL; two patients carried p.Ala59Thr (c.175G>A; rs9904366) and three p.Arg928Cys (c.2782C>T; rs35037984). Four other variations were identified, i.e., p.Cys112Ser (c.335G>C; rs141540493), p.Val781Ile (c.2342G>A;

Role of *UNC13D* Gene in ALPS/DALD Development

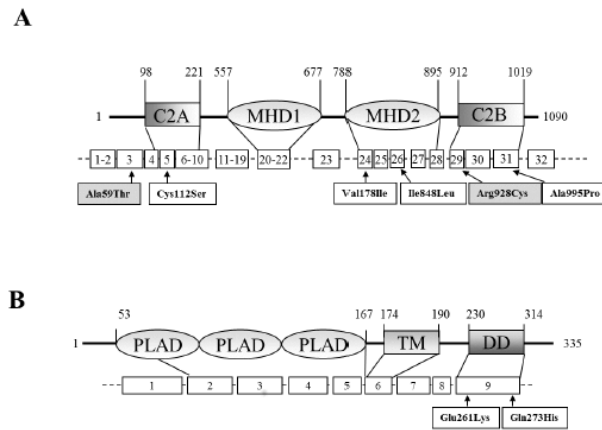

**Figure 1. *UNC13D* and *FAS* variations carried by ALPS/DALD patients.** Graphical representation (not in scale) of the Munc13-4 [A] and Fas [B] proteins (upper schemes: numbers indicate the amino acid positions) and genes (lower scheme: boxes represent the exons; arrows indicate the mutations). C2: C2 domain; MHD: Munc13-homology domain. PLAD: preligand assembly domain; TM: transmembrane domain; DD: death domain.

doi: 10.1371/journal.pone.0068045.g001

**Table 1. Gene variations detected in patients with ALPS or DALD.**

Patients		Diagnosis		Fas function*		FAS		UNC13D	
(gender)	Pt	Pt	F	M	Variation	Inh†	Variation	Inh†	
Pt.1 (female)	ALPS-FAS	D	D	N	p.Gln273His (c.819G>C)	F	p.Arg928Cys (c.2782C>T)	M or F‡	
Pt.2 (male)	ALPS-FAS	D	ND	ND	p.Glu261Lys (c.755G>A)	F	p.Cys112Ser (c.335C>G)	M	
Pt.3 (female)	ALPS-U	D	D	D			p.Ala59Thr (c.175G>A)	M	
Pt.4 (male)	ALPS-U	D	D	D			p.Ile848Leu (c.2542A>C)	M	
							p.Ala995Pro (c.2983G>C)	M	
Pt.5 (female)	ALPS-U	D	ND	ND			p.Val178Ile (c.2342G>A)	ND	
Pt.6 (male)	DALD	D	D	D			p.Ala59Thr (c.175G>A)	F	
Pt.7 (female)	DALD	D	D	D			p.Arg928Cys (c.2782C>T)	M	
Pt.8 (male)	DALD	D	D	ND			p.Arg928Cys (c.2782C>T)	ND	

\* D = defective, N = normal, Pt = patient, F = father, M = mother

† Inheritance, F = father, M = mother; ND = not determined; no parent displayed ALPS, DALD, XLP, or FHL; Pt.1's mother had rheumatoid arthritis.

‡ both parents carried the variation.

**Table 2.** Missense variations detected in 21 ALPS, 20 DALD, 38 MS patients, and 61 healthy controls.

Functional effect <sup>‡</sup>	ALPS (N=42)*	DALD (N=40)*	Controls (N=122)*	MS (N=76)*	
<b>Frequent variations<sup>†</sup></b>					
Arg928Cys	Not performed	1	2	8	2
Ala59Thr	Not performed	1	1	5	3
<i>Total alleles with frequent variations</i>	2	3	13	5	
<b>Private variations<sup>†</sup></b>					
Ile848Leu <sup>‡</sup>	Loss-of-function <sup>‡</sup>	1	0	0	0
Ala995Pro <sup>‡</sup>	Loss-of-function <sup>‡</sup>	1	0	0	0
Cys112Ser	Loss-of-function	1	0	0	0
Val781Ile	Loss-of-function	1	0	0	0
Pro271Ser	Normal Function	0	0	1	0
<i>Total alleles with loss of function</i>	3	0	0	0	

\* allele numbers

† amino acid substitution

‡ carried in the same allele

§ P value vs Controls (Fisher exact test)

rs149871493), p.Ile848Leu (c.2542A>C; rs144968313), and p.Ala995Pro (c.2983G>C; rs138760432). These variations have been recently described in the dbSNP database as rare variants with an allele frequency of <0.01%, and each variant was found in a single patient. Pt. 4 carried two variations, p.Ile848Leu and p.Ala995Pro, inherited from the same parent.

To assess the variation frequency in the general populations and in subjects with a different autoimmune disease, we sequenced *UNC13D* in 61 healthy controls and 38 patients with MS. The results showed that p.Ala59Thr was found in 5 healthy controls and 3 MS patients, and p.Arg928Cys in 8 healthy controls and 2 MS patients. Moreover, one healthy control carried the novel variation p.Pro271Ser (c.811C>T), absent in the other groups (Table 2). Because p.Ala59Thr and p.Arg928Cys were detected in all patients and control groups with similar allelic frequencies, they were not further considered. Because p.Cys112Ser, p.Val781Ile, p.Ile848Leu, and p.Ala995Pro were detected in the ALPS group alone, we further assessed their frequency in the Italian population by genotyping them in 100 additional healthy controls. None of these variations were identified in the healthy controls, indicating that their allele frequency is relatively low.

Of the five patients whose inheritance pattern of *UNC13D* variations could be determined, four (80%) were maternal and one (20%) was paternal (Table 1). To evaluate whether this apparent bias was due to genetic imprinting favoring expression of the maternal allele, we performed RT-PCR on mRNA derived from Pt.2, Pt.7, and two other patients who were heterozygous for the common synonymous polymorphism c.3198A>G (p.Gln1066Gln). Complementary DNA were then cloned, and 30 independent clones were sequenced for each patient. The results showed that both alleles were expressed at approximately the same levels in each subject, which did not

support maternal genetic imprinting in these patients (data not shown).

### Functional analyses

Fas-induced cell death assessed in T cells from the ALPS and DALD patients carrying the *UNC13D* variations is shown in Figure 2A. All patients displayed defective Fas function except for Pt.1, whose Fas function was considered as borderline with regard to statistical significance.

The FAS mutations present in Pt.1 and Pt.2 were p.Gln273His and p.Glu261Lys missense mutations, respectively. To assess their effect on Fas function, the wild-type (Fas<sup>WT</sup>) and mutated (Fas<sup>Gln273His</sup>, Fas<sup>Glu261Lys</sup>) forms of Fas cDNA were transfected into 293T cells. Twenty-four hours after transfection, 293T cells were harvested and caspase-8 activity was assessed in cell lysates. The results showed that caspase-8 activation was significantly lower in the cells transfected with Fas<sup>Gln273His</sup> and Fas<sup>Glu261Lys</sup> than in those transfected with Fas<sup>WT</sup> (Figure 2B).

The effects of the *UNC13D* missense variations on Munc13-4 protein expression and NK function were evaluated in the PBMC of all patients. NK function was evaluated by assessing the cytotoxic activity of resting NK cells against K562 cells and that of activated NK cells against the HLA-class I-negative B-EBV cell line 721.221. Resting and activated NK cells were also tested for granule exocytosis, the most appropriate assay to detect Munc13-4 defects [28]. The results showed that values were in the normal range for all patients (data not shown), which was consistent with previous data on donors carrying heterozygous mutations of *UNC13D*.

To further assess the functional effect of the *UNC13D* variations detected in one subject only, they were inserted into a cDNA encoding *UNC13D* fused to the SV5 epitope tag. The Munc13-4<sup>wt</sup>, Munc13-4<sup>Cys112Ser</sup>, Munc13-4<sup>Val781Ile</sup>, Munc13-4<sup>Ile848Leu</sup>, Munc13-4<sup>Ala995Pro</sup>, Munc13-4<sup>Ile848Leu/Ala995Pro</sup>, and Munc13-4<sup>Pro271Ser</sup> constructs were transfected into the HMC-1 mastocytoma cell line. Western blot analysis showed that all constructs were expressed at similar levels indicating that the polymorphisms did not have a substantial effect on Munc13-4 expression (data not shown). To assess the effect of these variations on Munc13-4 function, we evaluated the capacity of fMLP to induce secretory granule fusion with the plasma membrane in HMC-1 cells. Fusion was monitored by an increase in CD63 expression on the cell surface. Figure 3 shows that fMLP increased surface expression of CD63 by similar amounts in the cells transfected with Munc13-4<sup>wt</sup> or Munc13-4<sup>Pro271Ser</sup> constructs. In contrast, fMLP increased CD63 expression to a significantly lower extent in cells that have been transfected with the Munc13-4<sup>Cys112Ser</sup>, Munc13-4<sup>Val781Ile</sup>, Munc13-4<sup>Ile848Leu</sup>, Munc13-4<sup>Ala995Pro</sup>, and Munc13-4<sup>Ile848Leu/Ala995Pro</sup> constructs (\*p<0.05).

### Discussion

Munc13-4 is a member of the Munc13-like family of proteins. It is highly expressed in CTL, NK cells, and mast cells and it is involved in granule exocytosis. Once granules are tethered to the plasma membrane, a priming step is required to enable

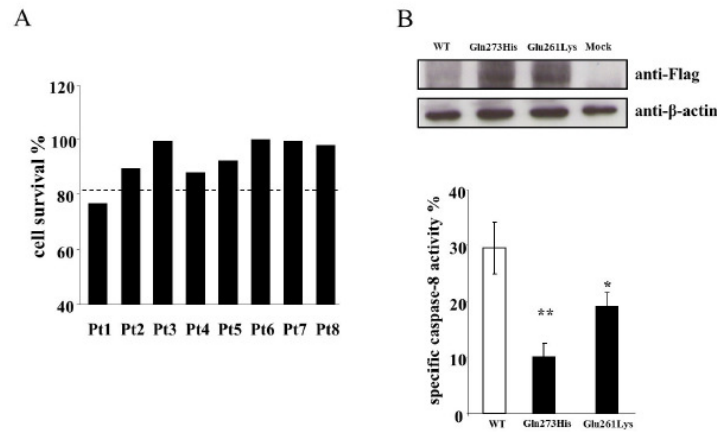
Role of *UNC13D* Gene in ALPS/DALD Development

**Figure 2. Defective Fas function in the ALPS and DALD patients carrying the *UNC13D* variations.** [A] Fas-induced cell death in T cells from the ALPS and DALD patients carrying the *UNC13D* variations. Activated T cells were treated with anti-Fas mAb and survival was assessed after 18 hours. The results are expressed as specific cell survival %. The dotted line indicates the upper limit of the normal range calculated as the 95<sup>th</sup> percentile of data obtained from 200 healthy controls; two or more were run in each experiment as positive controls; each patient was evaluated at least twice with the same result. [B] Fas expression and caspase-8 activity in lysates of 293T cells transfected with the wild-type (WT) or mutated form of *FAS* (Pt.1: p.Gln273His, Pt.2: p.Gln261Lys); cells were lysed 24 hours after transfection. *Upper panels*: Western blot analysis of the transfected *Fas* performed using anti-FLAG and anti- $\beta$ -actin antibodies. *Lower panels*: fluorimetric enzyme assay for caspase-8 activity. Data are relative to those displayed by mock-transfected cells and are expressed as the mean and SE of the results from 4 experiments performed in duplicate. \* $p < 0.05$ ; \*\* $p < 0.01$  vs. *Fas*<sup>wt</sup> transfected cells.

doi: 10.1371/journal.pone.0068045.g002

fusion of the granule membrane with the plasma membrane. In this priming step, granules interact with a docking complex composed of Munc18-2 and Syntaxin-11. Thus, Munc13-4 triggers the switch of syntaxin-11 from a closed to an open conformation enabling fusion [29].

The present study detected six missense variations of *UNC13D* in ALPS-FAS (2/7, 29%), ALPS-U (3/14, 21%), and DALD (3/20, 15%) patients. Among them, two (p.Ala59Thr, p.Arg928Cys) had been previously reported in FHL3, whereas the other four (p.Cys112Ser, p.Val781Ile, p.Ile848Leu, p.Ala995Pro) were reported in the dbSNP database as rare variations with unknown functional and pathological significance. Moreover, both Ile848Leu and Ala995Pro have been described in *cis* in one patient with systemic Juvenile Idiopathic Arthritis (SJIA) and patients with FHL [30].

Only p.Ala59Thr and p.Arg928Cys were found in more than one patient, with the former carried by an ALPS-U and a DALD patient, and the latter by an ALPS-FAS and two DALD patients. These p.Ala59Thr and p.Arg928Cys variations were detected in several healthy controls and MS patients with similar allelic frequencies (p.Ala59Thr: ALPS 2.4%, DALD 2.5%, healthy controls 4.1%, MS 4%; p.Arg928Cys: ALPS 2.4%, DALD 5%, healthy controls 6.5%, MS 2.6%). These data argue against substantial role for these variations in ALPS and DALD. The p.Ala59Thr variation had been previously reported in two families with FHL, but always in *cis* with a pathogenic mutation,

making it difficult to assess its contribution to pathogenesis [31]. The p.Arg928Cys variation had been previously reported in FHL patients and a recent genotype-phenotype study detected it in 8 patients carrying biallelic *UNC13D* mutations from 7 unrelated families [27]; yet, some of these FHL3 patients had a third missense mutation too. However, it could be a mild variant whose effect could not be detected in the small groups of subjects used in our study.

The other four variations were carried by three ALPS patients and were absent in DALD and MS patients, and in the healthy controls. The p.Cys112Ser variation was detected in an ALPS-FAS patient who also carried a *FAS* mutation (p.Gln261Lys); the *FAS* and the *UNC13D* mutations were inherited from the father and the mother, respectively. The p.Ile848Leu and p.Ala995Pro variations were carried by an ALPS-U patient and were in *cis*, as previously reported in SJIA and FHL [30], because both of them were inherited from the mother. The p.Val781Ile variation was detected in an ALPS-U patient. These variations were located within key functional domains of Munc13-4, characterized by two C2 domains (C2A, C2B) separated by long sequences containing two Munc13-homology domains (MHD) [29,32–34]. C2 domains bind calcium ions and are involved in targeting proteins to cell membranes; MHD domains are essential for the cellular localization of Munc13-4. The p.Cys112Ser variation was located in the C2A domain, p.Val781Ile and p.Ile848Leu in the

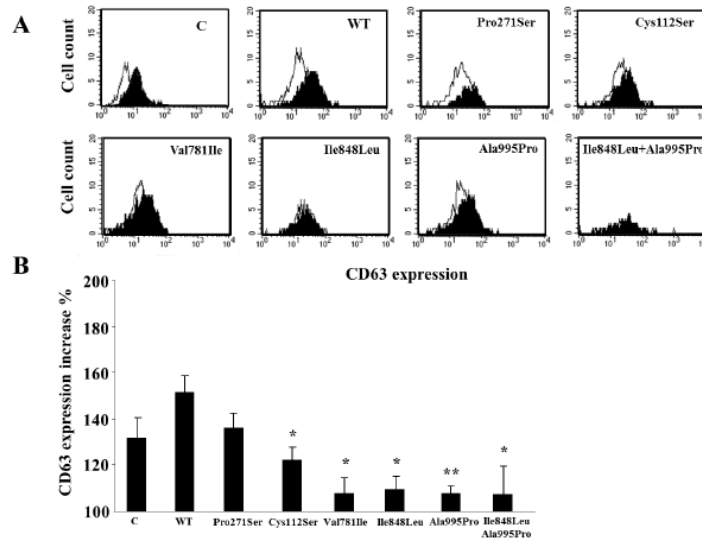
Role of *UNC13D* Gene in ALPS/DALD Development

**Figure 3. Functional effect of the “private” missense variations of *UNC13D*.** HMC-1 cells were transiently transfected with wild-type (WT) *UNC13D* and mutated forms carrying the (p.Cys112Ser, p.Val781Ile, p.Ile848Leu, p.Ala995Pro, p. Ile848Leu/p.Ala995Pro, and p.Pro271Ser) variations (C = untransfected cells). Twenty-four hours after transfection, cells were treated (or not) for 10 min with fMLP, and expression of CD63 was evaluated by flow cytometry. [A] Cytofluorimetric histograms of CD63 expression in fMLP-stimulated (black) and unstimulated (white) cells transfected with each construct; one experimental representative of six is shown. [B] Mean and SE of the fMLP-induced expression of CD63 from six experiments; results are relative to the CD63 expression displayed by unstimulated cells (set at 100%) in each experiment; the asterisk marks the statistically significant difference versus cells transfected with the WT form; \* $p < 0.05$ ; \*\* $p < 0.01$  vs  $MUNC^{wt}$  transfected cells.

doi: 10.1371/journal.pone.0068045.g003

MHD2 domain, and p.Ala995Pro in the C2B domain. The effect of these variations was assessed upon transfection in the HMC-1 mast cell line, commonly used to study granule exocytosis, which showed that all of them significantly decreased Munc13-4 function as detected by decreased fMLP-induced granule exocytosis. By contrast, one further variation (p.Pro271Ser) detected in a healthy control was located in the C2A domain but functional analysis showed that it did not significantly decrease Munc13-4 function.

The loss of function effects detected in the transfected cells are in contrast with the normal NK activity detected in the PBMC of the patients carrying the p.Cys112Ser, p.Val781Ile, p.Ile848Leu, and p.Ala995Pro variation. This discrepancy may be ascribed to a difference in sensitivity of the two types of assays. The NK function assays can, in fact, detect severe defects displayed by subjects carrying biallelic loss of function mutations of *PRF1* or *UNC13D*, but not the mild defect displayed by their healthy parents carrying monoallelic mutations. By contrast, mild defects could be detected by our assay in HMC-1 cells in which transfection forces expression of high levels of the Munc13-4 variants.

These data showed that rare loss of function variations of *UNC13D* are observed in ALPS patients with a higher

frequency (7%) than in the healthy control (0%), DALD (0%), and MS (0%) groups. Thus, these variations may have an impact in the development of ALPS. Support for this hypothesis comes from a patient who carried loss-of-function mutations in *FAS*, *UNC13D*, and *XIAP*. He was not included in this study because the genetic and clinical complexity of his picture fulfilled the diagnostic criteria of ALPS but also shared features of FHL and X-linked lymphoproliferative disease (Boggio E. et al, submitted).

Defective functions of Fas and Munc13-4 might cooperate in disrupting the ability of the immune system to shut off and interfere with the anti-viral response. These processes involve both Fas and NK/NKT cell function whose cytotoxicity is crucial for the clearance of virus-infected cells and the fratricide of activated immune cells [35]. Persistence of viral infection and an inability to switch off the immune response may contribute to the lymphocyte accumulation and the autoimmune reactions displayed by ALPS patients.

These data suggest that the *UNC13D* variations may be considered part of an oligogenic background, predisposing individuals to ALPS development. This may involve genes encoding for perforin (*PRF1*), osteopontin (*OPN*), and Signaling Lymphocyte Activation Molecule-Associated Protein

(*SH2D1A*), whose variations have been suggested to be risk factors for ALPS or DALD development. From this perspective, patients 1, 3, 4, 5, 6, 7, and 8 also notably carried the c. 1239A>C variation of *OPN*, associated with ALPS and DALD [36]. Further, patients 2 and 8 displayed hemizyosity for the -349T variation of *SH2D1A*, which has been associated with ALPS and DALD [37]. Finally, patient 7 also carried the p.Ala91Val variation of *PRF1*, which has been associated with DALD [22].

ALPS and DALD display a similar clinical picture and share an inherited defect of Fas function and the modifying effect exerted by variants of *OPN*, *PRF1*, and *SH2D1A*. However, DN T cell expansion is only present in ALPS, which may mark immunopathological differences because a direct role has been ascribed to these cells in ALPS development. This work shows that mutations of *UNC13D* may also represent an immunologic difference because they were detected in ALPS but not in DALD patients. Moreover, the *UNC13D* variations were not detected in MS patients, which suggested that they are not a

common risk factor for autoimmunity. However, a possible role of *UNC13D* in development of autoimmune diseases other than ALPS has been previously suggested in patients with SJIA [30,38], who may also display decreased NK function [39]. By contrast, the *OPN* and *PRF1* variants were involved in development of several other autoimmune diseases [40–47]. Future whole-genome or exome sequencing studies will reveal the complex genetic scenario that may contribute to ALPS and DALD.

### Author Contributions

Conceived and designed the experiments: MA SRE CD UR UD. Performed the experiments: VC EO ID SB MFS GC EB MM SM NC. Analyzed the data: DP AC. Contributed reagents/materials/analysis tools: UD UR. Wrote the manuscript: MA SRE CD UR UD. Recruitment and diagnosis of ALPS patients: SP UR. Recruitment and diagnosis of MS patients: CC.

### References

- Voskoboinik I, Dunstone MA, Baran K, Whisstock JC, Trapani JA (2010) Perforin: structure, function, and role in human immunopathology. *Immunol Rev* 235: 35–54. PubMed: 20536554.
- Lieberman J (2003) The ABCs of granule-mediated cytotoxicity: new weapons in the arsenal. *Nat Rev Immunol* 3: 361–370. doi:10.1038/nri1083. PubMed: 12766758.
- Aricò M, Danesino C, Pende D, Moretta L (2001) Pathogenesis of haemophagocytic lymphohistiocytosis. *Br J Haematol* 114: 761–769. doi:10.1046/j.1365-2141.2001.02936.x. PubMed: 11564062.
- Cetica V, Pende D, Griffiths GM, Aricò M (2010) Molecular basis of familial hemophagocytic lymphohistiocytosis. *Haematologica* 95: 538–541. doi:10.3324/haematol.2009.019562. PubMed: 20378576.
- Fisher GH, Rosenberg FJ, Straus SE, Dale JK, Middleton LA et al. (1995) Dominant interfering Fas gene mutations impair apoptosis in a human autoimmune lymphoproliferative syndrome. *Cell* 81: 935–946. doi:10.1016/0092-8674(95)90013-6. PubMed: 7540117.
- Rieux-Laucat F, Le Deist F, Hivroz C, Roberts IA, Debatin KM et al. (1995) Mutations in Fas associated with human lymphoproliferative syndrome and autoimmunity. *Science* 268: 1347–1349. doi:10.1126/science.7539157. PubMed: 7539157.
- Wu J, Wilson J, He J, Xiang L, Schur PH et al. (1996) Fas ligand mutation in a patient with systemic lupus erythematosus and lymphoproliferative disease. *J Clin Invest* 98: 1107–1113. doi:10.1172/JCI118892. PubMed: 8787672.
- Wang J, Zheng L, Lobito A, Chan FK, Dale J et al. (1999) Inherited human Caspase 10 mutations underlie defective lymphocyte and dendritic cell apoptosis in autoimmune lymphoproliferative syndrome type II. *Cell* 98: 47–58. doi:10.1016/S0092-8674(00)80605-4. PubMed: 10412980.
- Lenardo MJ, Oliveira JB, Zheng L, Rao VK (2010) ALPS—ten lessons from an international workshop on a genetic disease of apoptosis. *Immunity* 32: 291–295. doi:10.1016/j.immuni.2010.03.013. PubMed: 20346767.
- Oliveira JB, Bleesing JJ, Dianzani U, Fleisher TA, Jaffe ES et al. (2010) Revised diagnostic criteria and classification for the autoimmune lymphoproliferative syndrome (ALPS): Report from the 2009 NIH International Workshop. *Blood* 116: e35–e40. doi:10.1182/blood-2010-04-280347. PubMed: 20538792.
- Straus SE, Jaffe ES, Puck JM, Dale JK, Elkon KB et al. (2001) The development of lymphomas in families with autoimmune lymphoproliferative syndrome with germline Fas mutations and defective lymphocyte apoptosis. *Blood* 98: 194–200. doi:10.1182/blood.V98.1.194. PubMed: 11418480.
- Krammer PH (2000) CD95's deadly mission in the immune system. *Nature* 407: 789–795. doi:10.1038/35037728. PubMed: 11048730.
- Dianzani U, Chiochetti A, Ramenghi U (2003) Role of inherited defects decreasing Fas function in autoimmunity. *Life Sci* 72: 2803–2824. doi:10.1016/S0024-3205(03)00196-6. PubMed: 12697265.
- Carroll HP, Ali S, Kirby JA (2001) Accelerating the induction of Fas-mediated T cell apoptosis: a strategy for transplant tolerance? *Clin Exp Immunol* 126: 589–597. doi:10.1046/j.1365-2249.2001.01706.x. PubMed: 11737081.
- Nagata S (1997) Apoptosis by death factor. *Cell* 88: 355–365. doi:10.1016/S0092-8674(00)81874-7. PubMed: 9039262.
- Dianzani U, Bragardo M, DiFranco D, Alliaudi C, Scagni P et al. (1997) Deficiency of the Fas apoptosis pathway without Fas gene mutations in pediatric patients with autoimmunity/lymphoproliferation. *Blood* 89: 2871–2879. PubMed: 9108407.
- Ramenghi U, Bonisconi S, Migliaretti G, DeFranco S, Bottarel F et al. (2000) Deficiency of the Fas apoptosis pathway without Fas gene mutations is a familial trait predisposing to development of autoimmune diseases and cancer. *Blood* 95: 3176–3182. PubMed: 10807785.
- Campagnoli MF, Garbarini L, Quarello P, Garelli E, Carando A et al. (2006) The broad spectrum of autoimmune lymphoproliferative disease: molecular bases, clinical features and long-term follow-up in 31 patients. *Haematologica* 91: 538–541. PubMed: 16537120.
- Nagata S, Suda T (1995) Fas and Fas ligand: lpr and gld mutations. *Immunol Today* 16: 39–43. doi:10.1016/0167-5699(95)80069-7. PubMed: 7533498.
- Jackson CE, Fischer RE, Hsu AP, Anderson SM, Choi Y et al. (1999) Autoimmune lymphoproliferative syndrome with defective Fas: genotype influences penetrance. *Am J Hum Genet* 64: 1002–1014. doi:10.1086/302333. PubMed: 10090885.
- Clementi R, Dagna L, Dianzani U, Dupré L, Dianzani I et al. (2004) Inherited perforin and Fas mutations in a patient with autoimmune lymphoproliferative syndrome and lymphoma. *N Engl J Med* 351: 1419–1424. doi:10.1056/NEJMoa041432. PubMed: 15459303.
- Clementi R, Chiochetti A, Cappellano G, Cerutti E, Ferretti M et al. (2006) Variations of the perforin gene in patients with autoimmunity/lymphoproliferation and defective Fas function. *Blood* 108: 3079–3084. doi:10.1182/blood-2006-02-001412. PubMed: 16720836.
- Butterfield JH, Weiler D, Dewald G, Gleich GJ (1988) Establishment of an immature mast cell line from a patient with mast cell leukemia. *Leuk Res* 12: 345–355. doi:10.1016/0145-2126(88)90050-1. PubMed: 3131594.
- Pivot-Pajot C, Varoquaux F, de Saint Basile G, Bourgoin SG (2008) Munc13-4 regulates granule secretion in human neutrophils. *J Immunol* 180: 6786–6797. PubMed: 18453599.
- De Franco S, Chiochetti A, Ferretti M, Castelli L, Cadario F et al. (2007) Defective function of the Fas apoptotic pathway in type 1 diabetes mellitus correlates with age at onset. *Int J Immunopathol Pharmacol* 20: 567–576. PubMed: 17880769.
- Marcenaro S, Gallo F, Martini S, Santoro A, Griffiths GM et al. (2006) Analysis of natural killer-cell function in familial Hemophagocytic lymphohistiocytosis (FHL): defective CD107a surface expression heralds Munc13-4 defect and discriminates between genetic subtypes



Role of *UNC13D* Gene in ALPS/DALD Development

- of the disease. *Blood* 108: 2316-2323. doi:10.1182/blood-2006-04-015693. PubMed: 16778144.
27. Sieni E, Cetica V, Santoro A, Beutel K, Mastrodicasa E et al. (2011) Genotype-phenotype study of familial haemophagocytic lymphohistiocytosis type 3. *J Med Genet* 48: 343-352. doi:10.1136/jmg.2010.085456. PubMed: 21248318.
  28. Bryceson YT, Pende D, Maul-Pavicic A, Gilmour KC, Ufheil H et al. (2012) A prospective evaluation of degranulation assays in the rapid diagnosis of familial hemophagocytic syndromes. *Blood* 119: 2754-2763. doi:10.1182/blood-2011-08-374199. PubMed: 22294731.
  29. de Saint Basile G, Ménasché G, Fischer A (2010) Molecular mechanisms of biogenesis and exocytosis of cytotoxic granules. *Nat Rev Immunol* 10: 568-579. doi:10.1038/nri2803. PubMed: 20634814.
  30. Zhang K, Biroshak J, Glass DN, Thompson SD, Finkel T et al. (2008) Macrophage activation syndrome in patients with systemic juvenile idiopathic arthritis is associated with MUNC13-4 polymorphisms. *Arthritis Rheum* 58: 2892-2896. doi:10.1002/art.23734. PubMed: 18759271.
  31. Santoro A, Cannella S, Bossi G, Gallo F, Trizzino A et al. (2006) Novel Munc13-4 mutations in children and young adult patients with haemophagocytic lymphohistiocytosis. *J Med Genet* 43: 953-960. doi:10.1136/jmg.2006.041863. PubMed: 16825436.
  32. Feldmann J, Callebaut I, Raposo G, Certain S, Bacq D et al. (2003) Munc13-4 is essential for cytolytic granules fusion and is mutated in a form of familial hemophagocytic lymphohistiocytosis (FHL3). *Cell* 115: 461-473.
  33. Ménager MM, Ménasché G, Romao M, Knapnougel P, Ho CH et al. (2007) Secretory cytotoxic granule maturation and exocytosis require the effector protein hMunc13-4. *Nat Immunol* 8: 257-267. doi:10.1038/ni1431. PubMed: 17237785.
  34. Rudd E, Bryceson YT, Zheng C, Edner J, Wood SM et al. (2008) Spectrum, and clinical and functional implications of UNC13D mutations in familial haemophagocytic lymphohistiocytosis. *J Med Genet* 45: 134-141. PubMed: 17993578.
  35. Lünemann A, Lünemann JD, Münz C (2009) Regulatory NK-cell functions in inflammation and autoimmunity. *Mol Med* 15: 352-358. PubMed: 19603102.
  36. Chiocchetti A, Indelicato M, Bensi T, Mesturini R, Giordano M et al. (2004) High levels of osteopontin associated with polymorphisms in its gene are a risk factor for development of autoimmunity/lymphoproliferation. *Blood* 103: 1376-1382. PubMed: 14592838.
  37. Boggio E, Melensi M, Bocca S, Chiocchetti A, Comi C et al. (2012) The -346T polymorphism of the SH2D1A gene is a risk factor for development of autoimmunity/lymphoproliferation in males with defective Fas function. *Hum Immunol* 73: 585-592. doi:10.1016/j.humimm.2012.02.025. PubMed: 22425739.
  38. Hazen MM, Woodward AL, Hofmann I, Degar BA, Grom A et al. (2008) Mutations of the hemophagocytic lymphohistiocytosis-associated gene UNC13D in a patient with systemic juvenile idiopathic arthritis. *Arthritis Rheum* 58: 567-570. doi:10.1002/art.23199. PubMed: 18240215.
  39. Villanueva J, Lee S, Giannini EH, Graham TB, Passo MH et al. (2005) Natural killer cell dysfunction is a distinguishing feature of systemic onset juvenile rheumatoid arthritis and macrophage activation syndrome. *Arthritis Res Ther* 7: R30-R37. doi:10.1186/ar1551. PubMed: 15642140.
  40. Orilieri E, Cappellano G, Clementi R, Cometa A, Ferretti M et al. (2008) Variations of the perforin gene in patients with type 1 diabetes. *Diabetes* 57: 1078-1083. doi:10.2337/db07-0947. PubMed: 18198357.
  41. Cappellano G, Orilieri E, Comi C, Chiocchetti A, Bocca S et al. (2008) Variations of the perforin gene in patients with multiple sclerosis. *Genes Immun* 9: 438-444. doi:10.1038/gene.2008.35. PubMed: 18496551.
  42. Solomou EE, Gibellini F, Stewart B, Malide D, Berg M et al. (2007) Perforin gene mutations in patients with acquired aplastic anemia. *Blood* 109: 5234-5237. doi:10.1182/blood-2006-12-063495. PubMed: 17311987.
  43. Vastert SJ, van Wijk R, D'Urbano LE, de Vooght KM, de Jager W et al. (2010) Mutations in the perforin gene can be linked to macrophage activation syndrome in patients with systemic onset juvenile idiopathic arthritis. *Rheumatology (Oxford)* 49: 441-449. doi:10.1093/rheumatology/kep418. PubMed: 20019066.
  44. Chiocchetti A, Comi C, Indelicato M, Castelli L, Mesturini R et al. (2005) Osteopontin gene haplotypes correlate with multiple sclerosis development and progression. *J Neuroimmunol* 163: 172-178. doi:10.1016/j.jneuroim.2005.02.020. PubMed: 15885319.
  45. Chiocchetti A, Orilieri E, Cappellano G, Barizzone N, D'Alfonso S et al. (2010) The osteopontin gene +1239A/C single nucleotide polymorphism is associated with type 1 diabetes mellitus in the Italian population. *Int J Immunopathol Pharmacol* 23: 263-269. PubMed: 20378012.
  46. Barizzone N, Marchini M, Cappiello F, Chiocchetti A, Orilieri E et al. (2011) Association of osteopontin regulatory polymorphisms with systemic sclerosis. *Hum Immunol* 72: 930-934. doi:10.1016/j.humimm.2011.06.009. PubMed: 21763380.
  47. Comi C, Cappellano G, Chiocchetti A, Orilieri E, Buttini S et al. (2012) The Impact of Osteopontin Gene Variations on Multiple Sclerosis Development and Progression. *Clin Dev Immunol*, 2012: 212893. PubMed: 23008732.

## SECTION 2

### Role of osteopontin in MS development and progression

#### 2.1 Background: OPN, role in immune regulation and association with MS

Osteopontin (OPN) is a glycosylated phosphoprotein, expressed in a variety of tissues and cells and secreted into body fluids. It was firstly discovered as a bone matrix protein and subsequently identified as cytokine (early T cell activation, Eta-1) produced by activated T cells and transformed cell lines. OPN binds certain integrins and CD44 variants ubiquitously expressed, mediating cell adhesion, migration and survival in several cell types. Through these interactions OPN is involved in many physiological and pathological processes such as wound healing, bone turnover, tumorigenesis, inflammation, ischemia and immune responses. The OPN encoding gene, *SPP1* (secreted phosphoprotein 1), formed by 7 exons and 6 introns, is mapped on human chromosome 4q21-q25. The full-length protein is composed of 324 amino acids, with a molecular weight that vary between 25 and 80 KDa, depending to post-translational modifications, that include glycosylation, phosphorylation and proteolytic cleavage by thrombin and MMPs, important for the protein function. OPN has a RGD (arginine-glycine-aspartate) domain, common to many extracellular matrix proteins, that is involved in the integrin engagements. After proteolytic cleavage by thrombin, OPN expose the peptide sequence SVVYGLR, important in promoting the adhesion of cells expressing  $\alpha 4$  and  $\alpha 9$  integrins ( $\alpha 9\beta 1$ ,  $\alpha 4\beta 7$ ), as leukocytes. OPN is also cleaved by MMPs, in particular MMP-3 and MMP-7 [51]. The protein also contains an aspartate-rich region, two heparin-binding site and a region near the C-terminus that binds specific CD44 variants, as v6- and v7- containing isoforms. Though this interaction, important for the immunomodulatory function of the protein, OPN reduces the expression of the anti-inflammatory cytokine IL-10 and favours the production of the pro-inflammatory IL-12, sustaining a Th1 response [52]. It has also been demonstrated that CD44-v6 blocks Fas-mediated apoptosis, probably interfering with the receptor trimerization, an important step for the activation of the apoptotic pathway. Moreover, it has been postulated that OPN may enhance the interaction of CD44-v6 with Fas, exerting in this way their anti-apoptotic ability [53]. Furthermore, an intracellular form of OPN (iOPN), generated by an alternative downstream translation start site, and lacking the N-terminal signal protein sequence has been described. iOPN favors the

polarization of Th17 cells, down-regulating the dendritic cells (DCs) production of the inhibitory cytokine IL-27 (inhibitor of IL-17) [54].

In the immune system, OPN is expressed by many different cell types including macrophages, neutrophils, DCs, NK cells, T and B lymphocytes [51]. Monocytes show low level of OPN that increase during differentiation. OPN is constitutively expressed in macrophages and regulates their functions such as migration, activation, phagocytosis, pro-inflammatory cytokine production and nitric oxide synthesis, in response to inflammatory stimuli. It also plays an important role in neutrophil recruitment at inflammatory sites, acting as a chemoattractant factor [51]. OPN is also involved in the regulation of DCs function: it is highly expressed in immature DCs and promotes their maturation, followed by their migration in peripheral lymph nodes, where they present processed antigens to naïve T cells [55]. It has also been demonstrated that OPN-activated DCs produce IL-12 and TNF- $\alpha$ , sustaining Th1 polarization [56]. As previously reported, OPN is secreted by activated T cells and is involved in cell-mediated immunity: OPN enhances Th1 response, supporting IFN- $\gamma$  production from T cells and IL-12 production from macrophages, but also inhibiting the production of IL-10 (Th2 response). It also modulates the proliferation and differentiation of T cells and induces B cell proliferation and antibody production.

All these findings can in part explain the pro-inflammatory capacity of OPN and its involvement in autoimmunity. The up-regulation of OPN has been linked to the pathogenesis of many autoimmune diseases such as MS, systemic lupus erythematosus (SLE), rheumatoid arthritis, atherosclerosis and other inflammatory diseases including cardiovascular disease, inflammatory bowel disease and asthma [51]. The association with MS is supported by several findings. OPN is the cytokine mostly expressed in lesions from MS patients and [57] its levels are significantly higher in RRMS compared to patients with progressive courses of the disease, particularly during relapses [58, 59]. In addition, several evidences from EAE models demonstrate that OPN have an important role in inducing relapses and in the progression of the disease. In particular, it has been demonstrated that *SPP1* knock-out mice are resistant to the progressive form of EAE and the administration of OPN in those mice induce recurrent relapses, worsening paralysis and neurological deficits, including optic neuritis. OPN triggers neurological relapses through two mechanisms: on one hand, OPN stimulates myelin-specific T cells to expressed pro-inflammatory mediators, including Th1 and Th17 cytokines that are regulated by NF-KB (nuclear factor-KB). On the other hands, OPN inhibits FOXO3A-(forkhead box O3A)-dependent apoptosis of autoreactive immune cells. These OPN mediated signalling results in the survival of autoreactive T cells [60, 61].

Also Th17 cells play a role in the pathogenesis of MS. It has been demonstrated that OPN expression is increased in DCs during EAE and MS and induces the production of IL-17 by T cells, suggesting that OPN is a key mediator that amplifies the inflammatory process in MS and this relationship may be implicated in other autoimmune diseases [62].

Several genetic studies has been performed on the *SPP1* gene. It has been identified four OPN SNPs: +282T>C in exon 6 (rs4754), +750C>T in exon 7 (rs11226616), +1083A>G (rs1126772) and +1239A>C (rs9138) in the 3'-untranslated region (3'-UTR), forming three haplotype combinations (haplotype A: 282T-750C-1083A-1239A; haplotype B: 282C-750T-1083A-1239C; haplotype C: 282C-750T-1083G-1239C) that have been linked to several autoimmune disease [63-67]. In particular, carriers of haplotype B or C display about 1,5 higher risk of developing MS [65], type 1 diabetes [66] and SLE [64] and about 8 higher risk of developing ALPS [63], than haplotype A homozygotes. In addition, it has been demonstrated that these genotypes also correlate with OPN serum levels: haplotype B and C are associated to high OPN level than haplotype A homozygotes, probably due to the increased stability of mRNA coded by haplotype B and C [63]. Furthermore, haplotype A homozygous MS patients show a slower switch from a RR to a SP form and milder disease with slower evolution of disability in comparison to patients carrying haplotype B or C [65]. Moreover, in the promoter region of *SPP1* gene has been identified three SNPs that may modulate its transcriptional activity and include -66T>G, -156G>GG (rs7687316) and -443T>C [68]. It has been demonstrated a combined effect of -156G>GG and +1239A>C on risk of SLE development [64].

## 2.2 Rationale for study and specific aims

Several findings have demonstrated that OPN has a role in the pathogenesis of MS. In particular, OPN is highly expressed in MS lesions [57] and its levels are increased, mainly during relapses, in patients with RR course than in patients with progressive forms of the disease [58, 59].

A previous study on *SSP1* gene showed that haplotype A carriers have a 1,5 lower risk of developing MS than haplotype B or C carriers and they are characterized by a slower progression of the disease to SP form with slower evolution of disability than other patients [65]. The +1239A>G SNP is located on 3' end of the gene and allows to discriminate between haplotype A (carrying the +1239A allele) and haplotype B or C (carrying the +1239G allele). It has been demonstrated that this SNP and another one located in the promoter region of OPN gene (156G>GG) contribute to SLE susceptibility [64].

The following study [Article 2] aims at extending the analysis of +1239A>C SNP in a much larger cohort of MS patients compared to a previous study [65] and at investigating for the first time the

role of the -156G>GG SNP in the development of the disease. Moreover, this study also points at assessing the impact of these variations on disease evolution.

### **2.3 Results and conclusions**

By sequencing analysis, the +1239A>C SNP has been typed in 728 MS patients and 1218 healthy controls, while the -156G>GG SNP has been typed in the same patients and 912 controls. The frequency of +1239A homozygotes are decreased in MS patients than controls (46% vs 52%;  $p=0,011$ ) and they display 1,27 lower risk of MS than +1239C carriers. These findings confirm the previous results [65] and show that +1239A carriers display a slight protection against MS development. On the other hands, the analysis of the frequencies of -156G>GG SNP have not revealed any statistically significant difference between patients and controls. Nevertheless, the results from the impact of these variations on the MS course have been confirmed not only the correlation between +1239A>C SNP and disease progression, but also have been displayed a significantly lower relapse rate in +1239A homozygous patients, supporting the establish role of OPN in MS relapses. Intriguingly it has also been detected an additional effect of -156G>GG on disease progression since patients homozygous for both +1239A and -156GG show a milder disease, with slower switch from RR to SP form of MS and slower progression of disability than other patients, suggesting that -156GG homozygosity in the 5' end of the gene confer a further protection, especially in subject carrying the protective genotype at the 3' end of the gene.

## ARTICLE 2

Hindawi Publishing Corporation  
Clinical and Developmental Immunology  
Volume 2012, Article ID 212893, 6 pages  
doi:10.1155/2012/212893

### Research Article

## The Impact of Osteopontin Gene Variations on Multiple Sclerosis Development and Progression

**Cristoforo Comi,<sup>1,2</sup> Giuseppe Cappellano,<sup>1,3</sup> Annalisa Chiocchetti,<sup>1,3</sup> Elisabetta Orilieri,<sup>1,3</sup> Sara Buttini,<sup>1,2</sup> Laura Ghezzi,<sup>4</sup> Daniela Galimberti,<sup>4</sup> Franca Guerini,<sup>5</sup> Nadia Barizzone,<sup>1,3</sup> Franco Perla,<sup>6</sup> Maurizio Leone,<sup>1,2</sup> Sandra D'Alfonso,<sup>1,3</sup> Domenico Caputo,<sup>5</sup> Elio Scarpini,<sup>4</sup> Roberto Cantello,<sup>1</sup> and Umberto Dianzani<sup>1,3</sup>**

<sup>1</sup> Interdisciplinary Research Center of Autoimmune Diseases (IRCAD), University of Eastern Piedmont, "Amedeo Avogadro", Novara, Italy

<sup>2</sup> Section of Neurology, Department of Translational Medicine, University of Eastern Piedmont, "Amedeo Avogadro", Novara, Italy

<sup>3</sup> Department of Health Sciences, University of Eastern Piedmont, "Amedeo Avogadro", Novara, Italy

<sup>4</sup> Dino Ferrari Center, The University of Milan, Fondazione Cà Granda, IRCCS Ospedale Haggiò Policlinico, Milan, Italy

<sup>5</sup> Multiple Sclerosis Unit, Don C. Gnocchi Foundation, IRCCS, S. Maria Nascente, Milan, Italy

<sup>6</sup> Department of Neurology, Mondovì Hospital, Mondovì, Italy

Correspondence should be addressed to Cristoforo Comi, comi@med.unipmn.it

Received 15 June 2012; Revised 3 August 2012; Accepted 6 August 2012

Academic Editor: Timothy B. Niewold

Copyright © 2012 Cristoforo Comi et al. This is an open access article distributed under the Creative Commons Attribution License, which permits unrestricted use, distribution, and reproduction in any medium, provided the original work is properly cited.

Osteopontin is a proinflammatory molecule, modulating TH1 and TH17 responses. Several reports suggest its involvement in multiple sclerosis (MS) pathogenesis. We previously reported that OPN gene variations at the 3' end are a predisposing factor for MS development and evolution. In this paper, we extended our analysis to a gene variation at the 5' end on the -156G > GG single nucleotide polymorphism (SNP) and replicated our previous findings at the 3' end on the +1239A > C SNP. We found that only +1239A > C SNP displayed a statistically significant association with MS development, but both +1239A > C and -156G > GG had an influence on MS progression, since patients homozygous for both +1239A and -156G alleles displayed slower progression of disability and slower switch to secondary progression than those carrying +1239C and/or -156G and those homozygous for +1239A only. Moreover, patients homozygous for +1239A also displayed a significantly lower relapse rate than those carrying +1239C, which is in line with the established role of OPN in MS relapses.

### 1. Introduction

Multiple sclerosis (MS) is an inflammatory disease of the central nervous system characterized by an autoimmune response against the myelin sheaths and axons, resulting in progressive neurological dysfunction [1]. Patients with MS display variable clinical course; at onset, approximately 10% of patients display a primary progressive form (PP), whereas the remainder start out with a relapsing remitting form (RR), and most of them switch to a secondary progressive form (SP) within 10–30 years [2]. Both genetic and environmental factors are involved in the development/progression of MS, and several studies point to a complex inheritance involving

interactions between combinations of loci that may influence the immune response [3, 4]. An increasing bulk of data suggest that osteopontin (OPN) may play a role in the pathogenesis of MS [5]. OPN is a 60 kDa-secreted phosphoprotein functioning as a free cytokine in body fluids or as an immobilized extracellular matrix molecule in mineralized tissue [6]. OPN serum levels are increased in several autoimmune diseases and may influence development of these diseases through the OPN immunoregulatory effects enhancing the proinflammatory T helper type 1 (TH1) and TH17 cell responses and inhibiting the TH2 responses [7].

OPN transcript is abundant in plaques dissected from brains of patients with MS, whereas it is absent in control

brain tissue; this finding has been confirmed in rat experimental autoimmune encephalomyelitis (EAE) by microarray cDNA analysis of spinal cord tissue [8]. OPN serum levels are higher in relapsing-remitting than in progressive patients, particularly during the relapse [9, 10]. Chowdhury et al. reported a correlation between cerebrospinal fluid (CSF) OPN levels and disease activity in patients with MS. These levels did not correlate with disability status but were higher in patients with active disease [11].

The human OPN gene (*OPN*) is located on chromosome 4q22.1, and single nucleotide polymorphisms (SNPs) are associated with development and/or disease activity of several autoimmune diseases [12–14]. A link between the gene and protein data was suggested by the correlation between some *OPN* genotypes and OPN serum levels [15]. Four SNPs of the *OPN* gene (+282T > C in exon VI: rs4754; +750C > T in exon VII: rs11226616; +1083A > G: rs1126772 and +1239A > C: rs9138) in 3' UTR form three haplotype combinations: haplotype A (282T-750C-1083A-1239A), haplotype B (282C-750T-1083A-1239C), and haplotype C (282C-750T-1083G-1239C). Carriers of haplotype B and C displayed higher OPN serum levels and higher risk of developing autoimmune diseases than haplotype A homozygotes. Several data suggested that the high OPN levels were due to increased stability of the mRNA coded by haplotype B and C [15]. Regarding MS, we previously found that haplotype A homozygotes displayed about 1.5 lower risk of developing MS and lower OPN serum levels than haplotype B or C carriers. Moreover, clinical analysis showed that haplotype A homozygous patients displayed slower switching from a RR to a SP form and milder disease with slower evolution of disability than patients carrying haplotype B or C [16].

Interindividual differences of OPN expression may be also influenced by variations in the promoter region of *OPN* that may modulate its transcriptional activity. This role has been suggested for the -66T > G [17], -156G > GG (rs7687316), and -443>T > C [17] SNPs by Giacomelli et al. [18], and we detected a combined effect of -156G > GG and +1239A > C on risk of systemic lupus erythematosus (SLE) development [14].

According to these findings, the aims of this study were (1) to replicate our previous findings on the +1239A>C SNP, (2) to investigate the role of the -156G > GG SNP, (3), to assess the impact of these variations on disease evolution.

## 2. Materials and Methods

**2.1. Patients.** We analyzed 728 Italian patients (278 males, 450 females; M/F: 0.62) with MS diagnosed according to the revised McDonald criteria [19] and 1218 randomly selected ethnically and age-matched healthy controls. Patients were consecutive patients enrolled from the Multiple Sclerosis Centers of the “Amedeo Avogadro,” University of Eastern Piedmont (Novara), the University of Milan, IRCCS Policlinico Hospital (Milan), the Don C Gnocchi Foundation, IRCCS, S Maria Nascente (Milan), and the “Santa Croce e Carle” Hospital (Cuneo), Italy. Their clinical and demographic features were similar to those of other series [20, 21].

Controls were consecutive Italian donors obtained from the transfusion services of the respective hospitals. Patients and controls were unrelated, Caucasian and Italian, matched for age and gender, with no family history of autoimmune diseases in first degree relatives. According to their clinical course, patients were defined as follows [22]:

RR: occurrence of exacerbations, each lasting at least 24 h and separated by at least one month of inactivity, with full recovery or sequelae ( $n = 447$ );

PP: steady worsening of symptoms and signs from onset for at least 6 months, whether superimposed with relapses or not, with occasional plateau and temporary minor improvements; ( $n = 71$ );

SP: initial RR course followed by steady worsening of symptoms and signs for at least 6 months, whether superimposed with relapses or not, with minor remissions, and plateau ( $n = 210$ ).

We performed an analysis of the following outcome measures: time to reach Kurtzke expanded disability status scale [23] (EDSS) score > 3.0 and time to reach a progressive course, since it was previously shown that OPN SNPs at the 3' UTR region may influence these measures in MS patients [16]. According to Hawkins and McDonnell [24], disease of patients who, after at least 10 years from onset, had a mild disability, that is, EDSS score  $\leq 3.0$ , was defined benign MS. Patients who reached secondary progression within 10 years from onset were defined fast progressive. Patients who did not reach the endpoints were excluded.

In RR patients, EDSS score was assessed in remission phase.

The annual relapse rate before treatment was collected in 327 patients with bout onset (RR patients and SP patients) [21]. Only relapses that occurred in the first three years of disease were included in the analysis.

Samples from patients with RR were drawn during remission. All patients gave their informed consent according to the Declaration of Helsinki [25]. The research was approved by the local ethical committee.

**2.2. DNA Analysis.** Genomic DNA was isolated from peripheral blood mononuclear cells (PBMCs) using standard methods and primers used to evaluate OPN SNPs were the following: 5'-gccgtgaattccacagccatg-3' (OPN F) 5'-ttgaa-tgtaataagaatttggtgg-3' (OPN R)(for +1239 SNP) and 5'-agcctctcaagcagtcac-3' (promo 1F) 5'-cctgtgttggtgaggatgt-3' (promo 1R) (for -156 SNP). PCR products were purified with the EXO/SAP kit (GE, Healthcare, Piscataway, NJ, USA). Sequencing was performed with the ABI PRISM BigDye™ Terminator kit (Applied Biosystems, Foster City, CA) on an automatic sequencer (Applied Biosystems 3100 Genetic Analyser) according to the manufacturer's instructions.

**2.3. OPN ELISA Assay.** Serum OPN concentrations were evaluated in a capture enzyme-linked immunoadsorbent assay (ELISA) according to the protocol provided by the manufacturer (Calbiochem, San Diego, CA). The optical density was measured at 450 nm with a microplate reader (Bio-Rad, Hercules, CA). The I-smart program was used to

create a regression curve. All assays were performed in duplicate, and the observer (E.O.) was blinded to the diagnosis.

**2.4. Statistical Analysis.** Allelic frequencies and outcome measures were compared with the chi-square test with the Yate's correction. Relapse rate was compared with the Mann-Whitney *U*-test. For the ELISA experiments, the approximation of population distribution to normality was tested by using statistics for kurtosis and symmetry. Results were asymmetrically distributed and consequently presented as median values and percentiles. ELISA data comparisons were performed with the nonparametric Mann-Whitney *U* test. All *P* values are 2-tailed and the significance cut-off was  $P < 0.05$ .

### 3. Results

We typed the +1239A > C SNP in 728 patients and 1218 controls and the -156G > GG SNP in 728 patients and 912 controls, not overlapping with the cohorts analyzed in our previous study [16]. The +1239A > C SNP was analysed because it allows to discriminate between the A and non-A haplotypes (not carrying versus carrying the +1239C allele, resp.).

Frequency of +1239A homozygotes was decreased in MS patients compared to controls (46% versus 52%;  $P = 0.011$ ), and +1239A homozygotes displayed 1.27 lower risk of MS than +1239C carriers (Table 1). These findings confirmed our previous results on different groups of 425 patients and 688 healthy controls, showing that carriers of the +1239A display a slight protection against MS development. Conversely, no statistically significant difference between patients and controls was found for the -156G>GG SNP (Table 2).

Genotypic distribution did not deviate significantly from the Hardy-Weinberg equilibrium in any group (data not shown).

The next step was to assess the impact of these variations on MS evolution, since we previously reported that +1239A homozygotes displayed slower disease progression and milder disability over time compared to +1239C carriers [16]. According to our previous work, disease progression was evaluated by comparing patients switching from RR to SP within 10 years from onset (fast progressive,  $n = 184$ ) and those remaining RR over 10 years (slow progressive,  $n = 444$ ) and disease severity was evaluated by comparing patients with an EDSS score  $\leq 3.0$  ten years or more after onset (benign MS,  $n = 194$ ) and those who reached a score  $> 3.0$  within ten years (non-benign MS,  $n = 446$ ).

Table 3 shows that the proportion of slow progressive patients was significantly higher in +1239A homozygotes than in +1239C carriers (80% versus 63%,  $P < 0.0001$ ), whereas no difference was found between -156GG homozygotes and -156G carriers (73% versus 70%,  $P = 0.3$ ). Patients homozygous for both +1239A and -156GG showed a significantly higher proportion of slow progressive patients than those carrying +1239C and/or -156G (95% versus

TABLE 1: Frequency distribution of OPN +1239A > C genotypes in MS patients and healthy controls.

Genotype SNP + 1239	*MS ( $n = 728$ )	†Controls ( $n = 1218$ )
AA	335 (46)	634 (52)
AC	314 (43)	486 (40)
CC	79 (11)	98 (8)
AA	335 (46)	634 (52)
Non-AA	393 (54)	584 (48)

‡OR = 1.27  $P = 0.011$  (95% CI: 1.05–1.54)

\*Multiple sclerosis patients.

†number of subjects and proportions are shown in the brackets. Genotypic distribution did not deviate significantly from the Hardy-Weinberg equilibrium in any group (data not shown).

‡Odds ratio (OR), 95% confidence limits (95% CI),  $\chi^2$  test calculated on allelic frequencies, and *P* values are 2-tailed.

TABLE 2: Frequency distribution of OPN-156G/GG genotypes in MS patients and healthy controls.

Genotype SNP -156	†MS ( $n = 728$ )	†Controls ( $n = 912$ )
GG/GG	78 (10.7)	112 (12.3)
G/GG	304 (41.8)	384 (42.1)
GG	346 (47.5)	416 (45.6)

‡OR = 0.91  $P = 0.25$  (95% CI: 0.79–1.06)

\*Multiple sclerosis patients.

†Number of subjects, proportions are shown in the brackets. Genotypic distribution did not deviate significantly from the Hardy-Weinberg equilibrium in any group (data not shown).

‡Odds ratio (OR), 95% confidence limits (95% CI),  $\chi^2$  test calculated on allelic frequencies, and *P* values are 2-tailed.

68%,  $P < 0.0001$ ) and those homozygous for +1239A only (95% versus 80%,  $P = 0.0094$ ).

Table 3 also shows that the proportion of benign MS patients was significantly higher in +1239A homozygotes than in +1239C carriers (38% versus 24%,  $P = 0.0001$ ) and in -156GG homozygotes than in -156G carriers (46% versus 28%,  $P = 0.0018$ ). Patients homozygous for both +1239A and -156GG showed a significantly higher proportion of benign MS patients than those carrying +1239C and/or -156G and those homozygous for +1239A only (52% versus 38%,  $P = 0.038$ ).

To further evaluate the clinical impact of OPN variations, we analyzed the relapse rate in bout-onset patients carrying different genotypes. Data were available for 327 patients (157 AA, 170 non-AA). The relapse rate was significantly lower in +1239A homozygotes than in +1239C carriers (0.5/yr versus 1.3/yr,  $P = 0.01$ ), whereas no difference was found between -156GG homozygotes and -156G carriers (0.8/yr versus 1.1/yr;  $P = 0.09$ ) or between subjects carrying both protective genotypes and those carrying at least one predisposing genotype (0.6/yr versus 1.2/yr;  $P = 0.06$ ) (Table 4).

Finally, we explored whether OPN serum levels varied in patients displaying different outcomes. Consistently, we found that benign patients, as well as slow progressive patients, showed significantly lower protein levels compared to nonbenign and fast progressive patients, respectively



TABLE 3: Frequency distribution of different outcomes in MS patients carrying different OPN genotypes.

Outcome	Genotypes					
	+1239A > C		-156GG > G		+1239A > C -156G > GG	
	AA	C	GG/GG	G	AA GG/GG	C G
Fast progressive <sup>b</sup>	57 (20)	127 (37)	18 (27)	166 (30)	3 (5)	181 (32)
Slow progressive <sup>a</sup>	228 <sup>c</sup> (80)	216 (63)	58 (73)	386 (70)	57 (95)	387 (68)
	$P < 0.0001^d$		$P = 0.311$		$P < 0.0001$	
Benign MS <sup>a</sup>	110 (38)	84 (24)	36 (46)	158 (28)	35 (52)	159 (28)
Non benign MS <sup>b</sup>	183 (62)	263 (76)	42 (54)	404 (72)	32 (48)	414 (72)
	$P = 0.0001$		$P = 0.0018$		$P = 0.0002$	

<sup>a</sup>Patients displaying RR form (slow progressive) or EDSS  $\leq 3$  (benign MS) after 10 years from onset.

<sup>b</sup>Number of patients displaying that disease status; proportions are shown in brackets.

Patients displaying either RR course and less than 10 years of followup (29/728) or PP course (71/728) were excluded from the analysis of progression. Patients displaying EDSS  $\leq 3.0$  and less than 10 years of followup (88/728) were excluded from the analysis of disability.

<sup>c</sup>Patients switching to SP form (fast progressive) or reaching EDSS  $> 3$  (non-benign MS) within 10 years from onset.

<sup>d</sup>Statistical analysis was performed by comparing the different outcomes with the  $\chi^2$  test.

Total number in the analysis of progression: 628 patients: 285 AA; 343 non-AA; 76 GG; 552 non-GG; 60 AAGG; 568 non-AAGG.

Total number in the analysis of course 640 patients: 293 AA, 347 non-AA; 78 GG, 562 non-GG; 67 AAGG, 573 non-AAGG.

TABLE 4: Relapse rate in patients with bout onset displaying different OPN genotypes.

Outcome measure	Genotype					
	AA	C	GG/GG	Non-GG	AAGG	CG
	N = 153	N = 174	N = 33	N = 294	N = 26	N = 301
Relapse rate	0.5 <sup>a</sup> (0.2–1)	1.3 (0.6–1.7)	0.8 (0.4–1.2)	1.1 (0.5–1.3)	0.6 (0.2–1.3)	1.2 (0.5–1.5)
	$P = 0.01^b$		$P = 0.09$		$P = 0.06$	

<sup>a</sup>Median values; interquartile ranges are shown in the brackets.

<sup>b</sup>Mann-Whitney *U* test.

(median value 132 versus 237 ng/mL, interquartile range 94–164 versus 189–289 ng/mL,  $P < 0.0001$ ; median value 154 versus 280 ng/mL, interquartile range 100–207 versus 228–341 ng/mL,  $P < 0.0001$ ).

#### 4. Discussion

This work stems from our previous observation of a protective effect of +1239A homozygosity at the 3' UTR of *OPN* for MS development and evolution. In our previous paper, this genotype decreased the risk of MS development by 1.56-fold [16]. The parallel observation of a combined effect of +1239C and -156G on risk of (SLE) development [14] prompted this work extending the *OPN* analysis in MS to -156GG > G.

The current data, obtained on a much larger independent population, replicated our previous findings on +1239A > C, showing that the frequency of +1239A homozygotes was decreased in MS patients and that these subjects displayed 1.27 lower risk of MS development than +1239C carriers. The same SNPs in the 3' UTR region of the *OPN* gene have been studied in 326 Spanish MS patients and 484 controls by other authors. They did not find statistically significant differences between patients and controls, and this apparent

discrepancy might be explained by differences in both size and ethnic background of the population under study [26].

By contrast, analysis of -156G > GG SNP did not detect statistically significant differences between patients and controls (OR 0.91,  $P = 0.25$ ), which indicated that this genetic variation was not associated to MS development. To our knowledge, this is the first paper on this SNP in the MS population.

The most intriguing results were those on the role of these SNPs on the MS course. On the one hand, this study not only confirmed the correlation between +1239A > C and disease progression, but also strengthened this finding showing that +1239A homozygotes displayed a lower relapse rate than the other patients. On the other hand, it detected an additional effect of -156G > GG on disease progression since patients homozygous for both +1239A and -156GG displayed a milder disease, with slower progression of disability and slower switch to secondary progression, than those carrying +1239C and/or -156G and those homozygous for +1239A only. Therefore, -156GG homozygosity in the 5' end of the gene conferred a further protection especially in subjects also carrying the protective genotype at the 3' end of the gene.

These protective effects might be related to functional outcomes of these *OPN* variations. In our previous work, in fact, we showed that +1293C was associated with a high

“baseline” production of serum OPN, possibly related to increased stability of the OPN mRNA [15]. Moreover, position -156 seems to fall in a putative binding site for a component of the RUNX family of transcription factors and might influence osteopontin expression [18].

A further point supporting a protective role of AA genotype is provided by the analysis of OPN serum levels in patients displaying different disease outcomes. As a matter of fact, patients showing increased frequency of AA genotype, that is, benign and slow progressive MS patients, displayed lower OPN levels. Moreover, our findings are in line with the work by Kariuki SN et al. who reported that OPN gene variants modulate cytokine levels in SLE [27].

In conclusion, this work confirms that osteopontin and the OPN gene may be involved in MS development and, especially, progression. These observations suggest that this cytokine may be a therapeutic target to counteract MS progression supporting the finding of Steinman et al. showing that anti-OPN antibodies ameliorate the disease course in experimental autoimmune encephalomyelitis [28].

### Acknowledgments

This work was partly supported by Fondazione Cariplo Ricerca (Milan), FISM 2012/R/12 (Genoa), Italian Ministry of Health (Giovani Ricercatori 2007, D.lgs 502/92), and Regione Piemonte (Piattaforme Innovative Project) (Turin).

### References

- [1] U. K. Zettl, O. Stüve, and R. Patejdl, “Immune-mediated CNS diseases: a review on nosological classification and clinical features,” *Autoimmunity Reviews*, vol. 11, pp. 167–173, 2012.
- [2] B. G. Weinschenker, “The natural history of multiple sclerosis,” *Neurologic Clinics*, vol. 13, no. 1, pp. 119–146, 1995.
- [3] M. Comabella and S. J. Khoury, “Immunopathogenesis of multiple sclerosis,” *Clinical Immunology*, vol. 142, pp. 2–8, 2012.
- [4] C. Comi, T. Fleetwood, and U. Dianzani, “The role of T cell apoptosis in nervous system autoimmunity,” *Autoimmunity Reviews*. In press.
- [5] M. Carecchio and C. Comi, “The role of osteopontin in neurodegenerative diseases,” *Journal of Alzheimer’s Disease*, vol. 25, no. 2, pp. 179–185, 2011.
- [6] K. X. Wang and D. T. Denhardt, “Osteopontin: role in immune regulation and stress responses,” *Cytokine and Growth Factor Reviews*, vol. 19, no. 5–6, pp. 333–345, 2008.
- [7] G. Murugaiyan, A. Mittal, and H. L. Weiner, “Increased osteopontin expression in dendritic cells amplifies IL-17 production by CD4<sup>+</sup> T cells in experimental autoimmune encephalomyelitis and in multiple sclerosis,” *Journal of Immunology*, vol. 181, no. 11, pp. 7480–7488, 2008.
- [8] D. Chabas, S. E. Baranzini, D. Mitchell et al., “The influence of the proinflammatory cytokine, osteopontin, on autoimmune demyelinating disease,” *Science*, vol. 294, no. 5547, pp. 1731–1735, 2001.
- [9] M. H. J. Vogt, S. Floris, J. Killestein et al., “Osteopontin levels and increased disease activity in relapsing-remitting multiple sclerosis patients,” *Journal of Neuroimmunology*, vol. 155, no. 1–2, pp. 155–160, 2004.
- [10] M. Comabella, I. Pericot, R. Goertsches et al., “Plasma osteopontin levels in multiple sclerosis,” *Journal of Neuroimmunology*, vol. 158, no. 1–2, pp. 231–239, 2005.
- [11] S. A. Chowdhury, J. Lin, and S. A. Sadiq, “Specificity and correlation with disease activity of cerebrospinal fluid osteopontin levels in patients with multiple sclerosis,” *Archives of Neurology*, vol. 65, no. 2, pp. 232–235, 2008.
- [12] A. Chiocchetti, E. Orilieri, G. Cappellano et al., “The osteopontin gene +1239A/C single nucleotide polymorphism is associated with type 1 diabetes mellitus in the Italian population,” *International Journal of Immunopathology and Pharmacology*, vol. 23, no. 1, pp. 263–269, 2010.
- [13] N. Barizzone, M. Marchini, F. Cappiello et al., “Association of osteopontin regulatory polymorphisms with systemic sclerosis,” *Human Immunology*, vol. 72, pp. 930–934, 2011.
- [14] S. D’Alfonso, N. Barizzone, M. Giordano et al., “Two single-nucleotide polymorphisms in the 5’ and 3’ ends of the osteopontin gene contribute to susceptibility to systemic lupus erythematosus,” *Arthritis and Rheumatism*, vol. 52, no. 2, pp. 539–547, 2005.
- [15] A. Chiocchetti, M. Indelicato, T. Bensi et al., “High levels of osteopontin associated with polymorphisms in its gene are a risk factor for development of autoimmunity/lymphoproliferation,” *Blood*, vol. 103, no. 4, pp. 1376–1382, 2004.
- [16] A. Chiocchetti, C. Comi, M. Indelicato et al., “Osteopontin gene haplotypes correlate with multiple sclerosis development and progression,” *Journal of Neuroimmunology*, vol. 163, no. 1–2, pp. 172–178, 2005.
- [17] S. Mochida, M. Hashimoto, A. Matsui et al., “Genetic polymorphisms in promoter region of osteopontin gene may be a marker reflecting hepatitis activity in chronic hepatitis C patients,” *Biochemical and Biophysical Research Communications*, vol. 313, no. 4, pp. 1079–1085, 2004.
- [18] F. Giacomelli, R. Marciano, A. Pistorio et al., “Polymorphisms in the osteopontin promoter affect its transcriptional activity,” *Physiological Genomics*, vol. 20, pp. 87–96, 2005.
- [19] C. H. Polman, S. C. Reingold, B. Banwell et al., “Diagnostic criteria for multiple sclerosis: 2010 revisions to the McDonald criteria,” *Annals of Neurology*, vol. 69, no. 2, pp. 292–302, 2011.
- [20] M. Trojano, C. Avolio, C. Manzari et al., “Multivariate analysis of predictive factors of multiple sclerosis course with a validated method to assess clinical events,” *Journal of Neurology Neurosurgery and Psychiatry*, vol. 58, no. 3, pp. 300–306, 1995.
- [21] L. Castelli, C. Comi, A. Chiocchetti et al., “ICOS gene haplotypes correlate with IL10 secretion and multiple sclerosis evolution,” *Journal of Neuroimmunology*, vol. 186, no. 1–2, pp. 193–198, 2007.
- [22] F. D. Lublin and S. C. Reingold, “Defining the clinical course of multiple sclerosis: results of an international survey,” *Neurology*, vol. 46, no. 4, pp. 907–911, 1996.
- [23] J. F. Kurtzke, “Rating neurologic impairment in multiple sclerosis: an expanded disability status scale (EDSS),” *Neurology*, vol. 33, no. 11, pp. 1444–1452, 1983.
- [24] S. A. Hawkins and G. V. McDonnell, “Benign multiple sclerosis? Clinical course, long term follow up, and assessment of prognostic factors,” *Journal of Neurology Neurosurgery and Psychiatry*, vol. 67, no. 2, pp. 148–152, 1999.
- [25] K. Case, “Protection of patients’ rights to privacy,” *British Medical Journal*, vol. 311, no. 7015, p. 1272, 1995.
- [26] A. Mas, A. Martínez, V. de las Heras et al., “The 795CT polymorphism in osteopontin gene is not associated with multiple

- sclerosis in Spanish population,” *Multiple Sclerosis*, vol. 13, no. 2, pp. 250–252, 2007.
- [27] S. N. Kariuki, J. G. Moore, K. A. Kirou, M. K. Crow, T. O. Utset, and T. B. Niewold, “Age- and gender-specific modulation of serum osteopontin and interferon- $\alpha$  by osteopontin genotype in systemic lupus erythematosus,” *Genes and Immunity*, vol. 10, no. 5, pp. 487–494, 2009.
- [28] L. Steinman, S. Youssef, N. Van Venrooij et al., “Response to Comment on: the influence of the proinflammatory cytokine, osteopontin, on autoimmune demyelinating disease,” *Science*, vol. 299, article 1845, 2003.

## SECTION 3

### Role of perforin gene in CIDP

#### 3.1 Background: perforin and its role in human diseases

Perforin is a pore-forming protein of about 67 kDa, expressed in cytotoxic lymphocytes (CTLs and NK cells), that has an important role in immune regulation and surveillance. It takes part at the perforin-dependent secretory granules death pathway: in particular it is stored in secretory granules and after their release in the immunological synapse, it polymerizes and forms a transmembrane pore allowing the entry of the pro-apoptotic serine proteases (granzymes) into the cytosol of target cells [43]. The human *PRF1* gene, located on chromosome 10q22, is composed of three exons, which exons 2 and 3 forms the coding sequence. Perforin is a multidomain protein of 555 amino acids. It is synthesized as inactive precursor containing an N-terminal leader peptide which is cleaved to the active form of protein characterized by a positively charged N-terminal peptide with lytic activity (lytic peptide). Perforin also contains one putative amphipathic  $\alpha$ -helical domain, in the centre of their sequence, which shares some similarity to membrane-attack complex (MAC)-like proteins, particularly C9 complement protein, involved in membrane insertion; two long regions of low homology at the N- and C-terminal to the MAC-like domain, characteristic of perforin and conserved through evolution; an epidermal growth factor (EGF)-like domain of unknown function and a carboxyl C2 domain, that binds calcium and it is important for the regulation of perforin cytotoxic activity [69]. In particular, it has been demonstrated that conserved aspartate residues at position 429, 435, 483 and 485 in the perforin C2 domain are essential for its calcium-dependent plasma membrane binding and cell lysis. Moreover, at acidic pH (<5) of granules, that is perforin storage condition, these residues are protonated (uncharged) and are incapable of binding calcium, preventing premature activation of perforin until exocytosis and protecting the cell from autolysis during their synthesis and trafficking [70]. Finally, the cleavage of the N-glycosylated C-terminus of the protein allows the C2 domain to bind the membrane [71].

As previously reported, mutations in *PRF1* gene account for up to 30% of all FHL2 cases and include frameshift, nonsense and missense mutations that compromise the cytotoxic lymphocyte function [72]. In addition, it has also been found that variations of *PRF1* gene are susceptible factors for the development of some autoimmune disease, such as ALPS/DALS [48], type 1 diabetes [73] and MS [50]. In particular, concerning lymphoproliferative disease with defective Fas function, two FHL2-

associated variations, N252S and A91V, have been linked respectively to ALPS and DALD, and intriguingly DALD patients that carried A91V and osteopontin gene variations have been an increased risk of developing the disease [48]. These variations with other six novel mutations (C999T, G1065A, G1428A, A1620G, G719A, C1069T) of *PRF1* gene have been also associated to MS. A91V has been the most frequent variation observed and increase the risk of MS of about 1,4-fold [50].

### **3.2 Rationale for study and specifics aims**

CIDP is a demyelinating autoimmune disease of PNS in which pathogenesis are involved humoral and cell-mediated immunity [27]. It has been demonstrated that Schwann cells, that forms the myelin sheath around neuronal axons, are able to induce the apoptosis of infiltrating T cells through Fas ligand and perforin pathways, providing a protection against immune attacks of PNS [74]. Moreover, Comi et al. have been reported that CIDP patients display defective Fas function, which also correlates to disease development and progression [31, 75, 76]. Defective Fas function has also been showed in MS patients [49], suggesting that defective Fas-mediated apoptosis may be involved in the development of diseases affecting the central and peripheral nervous system [77]. The findings that *PRF1* variations are susceptible factors for autoimmunity, as it has been previously demonstrated for ALPS/DALD [48] and MS [50], prompt to search for *PRF1* variations also in CIDP patients, aiming to investigate the role of perforin in the development of CIDP, as it has been performed in the following study.

### **3.3 Materials and methods**

#### **3.3.1 Patients**

Genomic DNA samples have been isolated using standard methods from peripheral blood of 94 CIDP patients, diagnosed according to the American Academy of Neurology criteria (Ad Hoc Subcommittee of the American Academy of Neurology AIDS Task Force) [78]. All patients underwent routine analyses to rule out other causes of neuropathy, CSF examination, and electrodiagnostic tests. Patients have been enrolled from the Neurology Departments of the following institutions: University of the Eastern Piedmont 'Amedeo Avogadro' Novara (6), University of Padua (33), University of Turin (31), and L. Sacco Hospital, University of Milan (24). It has been also analysed the genomic DNA of 158 healthy Italian donors as controls, which samples have been obtained from the transfusion services of the Neurology Departments of University of

the Eastern Piedmont 'Amedeo Avogadro' Novara. Patients and controls are unrelated, Caucasian and Italian, matched for age and gender and analysed in parallel.

### 3.3.2 DNA analysis

From DNA genomic samples of each subjects enrolled in this study, the entire coding region of *PRF1* (exon2 and exon3) has been amplified and sequenced as previously reported [48]. For allele-specific PCR the wild-type (4R) and mutant (4H) alleles have been independently amplified using specific PCR amplification of genomic DNA (forward primer: 4Rfor 5'-tctgcagctccatggcagtcgg-3' or 4Hfor 5'-tctgcagctccatggcagtcga-3'; reverse primer used for amplification of exon 2). R4H and A91V substitutions have been typed by using the same primers.

### 3.3.3 Statistical analysis

Allelic frequencies have been compared with the chi-square test with the Yates' correction. All *p* values are two-tailed and the significance cut-off is  $p < 0,05$ .

Putative functional significance of the missense variations have been evaluated with the PolyPhen program (<http://genetics.bwh.harvard.edu/pph>).

## 3.4 Results and conclusions

By sequencing *PRF1* coding region in 94 CIDP patients and 158 healthy matched controls three missense variations have been identified, C272T (rs35947132), G11A (rs35418374) and C1153T (numerations are referred to the GenBank cDNA clone M28393, ATG=1) that lead to A91V, R4H and R385W amino acids substitution at the protein level and a nonsense variation, C1267T, resulting in a premature stop codon (Q423X). A91V and R4H variations have been described in general population, nevertheless A91V has been previously associated to FLH2 [72], DALD [48] and MS [50], whereas R4H has been reported in a patient with acquired aplastic anemia [79]. The R385W has been described in a patient with lymphoma [80], instead Q423X variation is novel. The PolyPhen algorithm has been used to predict the functional effect of R385W missense variation and showed that may damage the function and structure of the protein (R385W: score=0,959). Indeed, the Q423X variation, may affect protein function missing the C2-domain, responsible for the calcium-dependent plasma membrane binding (**Figure 3.1, A-B**).

Moreover, it has also been identified two synonymous variations, C822T (rs885821) and C900T (rs885822) respectively, previously reported as common polymorphisms. Their frequencies have been similar in patients and controls (data not shown).

A91V is carried by 18 CIDP patients (16 heterozygotes and 2 homozygotes) and 9 healthy controls (all heterozygotes). Interestingly, R4H variation has been detected in heterozygosis in 1 CIDP

patient that has been also heterozygous for A91V variation. Through allele-specific PCR analysis the two variations have been found on different alleles (**Figure 3.1, C-D**).

Moreover, PolyPhen algorithm has predicted the functional effect of R4H missense variation may damage the function and structure of the protein (R4H: score=1).

**Figure 3.1:** On the left electropherograms of the variations R385W (**A**) and Q423X (**B**), carried by two different CIDP patients. On the right, electropherograms of biallelic mutations R4H (**C**) and A91V (**D**) found in a CIDP patient.

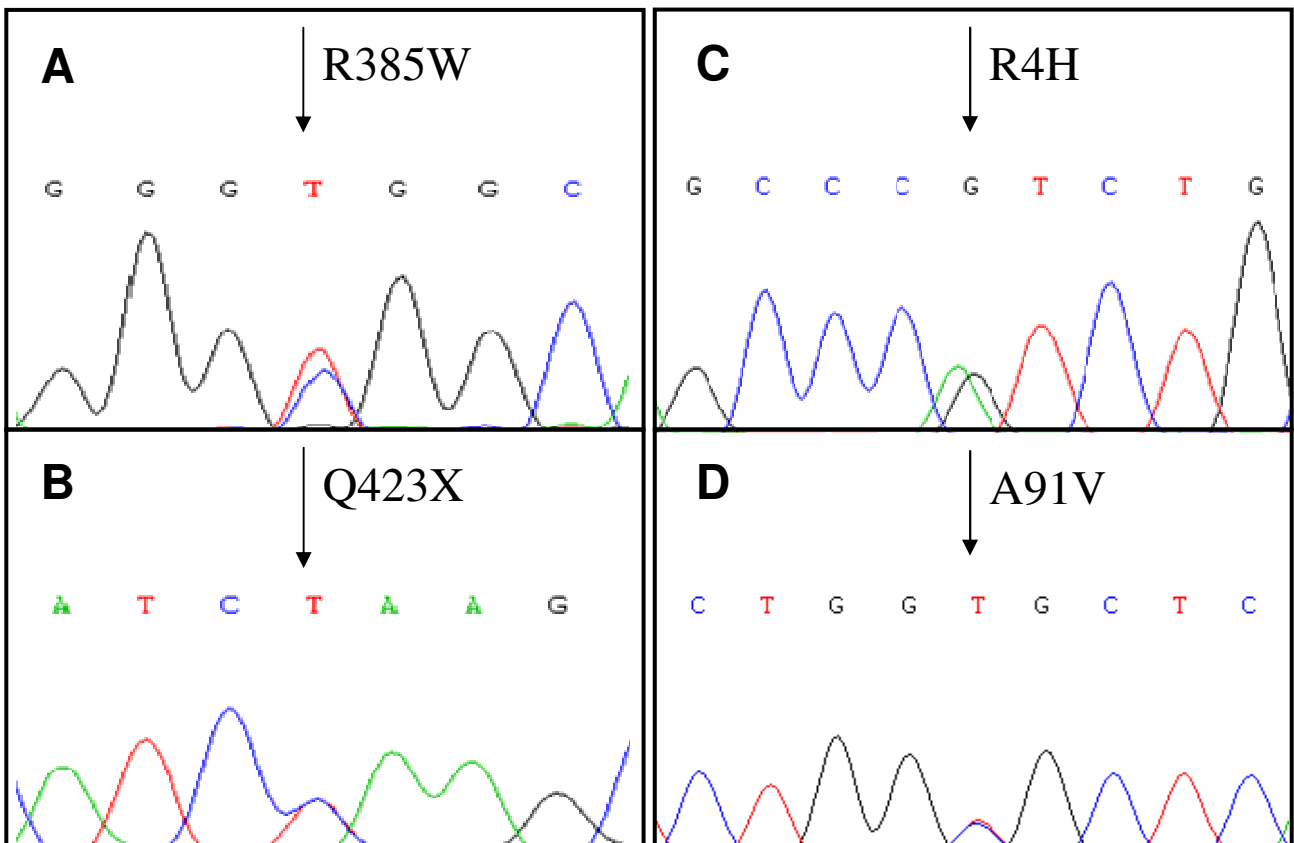

All together, the frequency of these variations are significantly higher in patients compared to the controls conferring a risk about 4,47-fold to develop CIDP (21,28% vs 5,69%; OR=4,47; 95% CI:1,82-11,22;  $p=0,00039$ ) (**Table 3.1**).

**Table 3.1:** Summary of the genotypes of 94 CIDP patients and 158 controls carrying *PRF1* variations.

Allele 1	Allele 2	CIDP (n=94) <sup>a</sup>	Controls (n=158) <sup>a</sup>
A91V	A91V	2	0
A91V	R4H	1	0
A91V	wt	15	9
R385W	wt	1	0
Q423X	wt	1	0
Total		20 (21.28%)	9 (5.69%)

<sup>b</sup>OR=4.47; 95% CI: 1.82-11.22; *p*=0.00039

Abbreviations: CI, confidence intervals; OR, odds ratio; wt, wild type. a: number of subjects (frequency in the brackets). b: OR and 95% CI limits; *p*-values are two-tailed.

Interestingly, A91V has been the most frequent variation identified in CIDP patients than controls, and by itself it confers a risk about 3,92-fold (OR=3,92, 95% CI:1,57-9,96; *p*=0,0017) (Table 3.2).

**Table 3.2:** Genotype frequencies of A91V in CIDP patients (n=94) and healthy controls (n=158).

Genotype	CIDP (n=94) <sup>a</sup>	Controls (n=158) <sup>a</sup>
AA	76 (0.81)	149 (0.94)
AV	16 (0.17)	9 (0.06)
VV	2 (0.02)	0 (0)

**AV+VV vs AA** <sup>b</sup>OR=3.92; 95% CI: 1.57-9.96; *p*=0.0017

Abbreviations: CI, confidence intervals; OR, odds ratio. a: Number of subjects; frequencies are shown in the brackets. Genotypic distribution did not deviate significantly from the Hardy–Weinberg equilibrium in any group (data not shown). b: OR and 95% CI limits; *p*-values are two-tailed.

The pathogenic role of A91V variation has been also supported by several functional studies, demonstrating an impaired protein expression and a partial loss of its cytolytic activity [81-83] and finally compromising the immune homeostasis if the variation is inherited in homozygosis or if it is coinherited with another mutated *PRF1* allele [84]. In this cohort of CIDP patients, 91V allele alone



has conferred a risk about 4-fold to develop CIDP; though almost of patients are carried this mutation in heterozygosis and only in 2 patients it is found in homozygosis. Interestingly, one patient is carried of the biallelic mutations: A91V and R4H respectively. R4H variation has been previously reported in heterozygosis in a patient with acquired aplastic anemia and this mutation resulted in null perforin protein expression and NK cells cytolytic activity [79]. This is also confirmed by PolyPhen algorithm which has been predicted that this variation is probably damaging, with maximum score. On the basis of these evidences, in this patient both variations might have contributed to its CIDP peculiar phenotype.

In addition, other *PRF1* variations have been found in CIDP patients. One patient is carried the R385W substitution previously described in a patient with lymphoma [80], but its functional effect has not been elucidated yet. *In silico* analysis performed by using PoliPhen software have been predicted that it may damage perforin structure and function. In another patient a novel variation Q423X of perforin has been found in heterozygosis, leading a truncated protein of C2-domain, involved in the calcium-dependent plasma membrane binding, responsible for its cytolytic activity [70]. In conclusion, this work suggests that private missense *PRF1* variations and the common A91V variation may have a mild effect on CIDP development, because most of them have been found in heterozygosis, by compromising one *PRF1* allele. Nevertheless, other clinical analysis are needed in CIDP patients that carried these variations, to further explore their impact on the course of the disease. These findings suggest that perforin may have both a protective and a detrimental role, depending on the local context and disease stage. On one side perforin physiologically protects peripheral nerve from autoimmune attacks as following its release by Schwann cells. On the other hand, CTLs released perforin may also contribute to the damage of peripheral nerve tissue too. Impaired perforin function in CIDP patients associated with defective Fas function may be responsible for defective apoptosis leading to demyelination; and from other point of view a reduction in its function when mutated may cause a mild axonal damage in patients carrying these mutations.

## SECTION 4

### Role of osteopontin in CIDP

#### 4.1 Rationale for study and specific aims

As of today, few evidences on the role of OPN in inflammatory polyneuropathies have been reported. It has been demonstrated that OPN is constitutively expressed in PNS and its expression is up-regulated in EAN model [85]. Furthermore it has been suggested that the interaction between OPN and CD44-v6 may be involved in the inhibition of Fas-mediated apoptosis [53] and Comi et al. have shown that Fas function is defective in CIDP patients [31]. In addition, it has been demonstrated that OPN enhances Th1 and Th17 responses, that are involved in the pathogenesis of several autoimmune diseases [51, 52]. The role of Th1 and Th17 cells in the pathogenesis of CIDP has not been established yet, however it has been recently reported that Th17 cells frequency is significantly higher in the peripheral blood mononuclear cells (PBMCs) and CSF of active CIDP patients in comparison to remitting CIDP patients, suggesting that these cells may be important for the evolution of the disease [86].

Based on this findings, this study aims to assess the role of OPN in the development of CIDP, evaluating OPN plasma levels through a ELISA assay in CIDP patients compared to healthy controls and typing the CIDP patients for the +1239A>C variation, located in 3' end of OPN gene.

#### 4.2 Materials and Methods

##### 4.2.1 Patients

Genomic DNA has been analysed in 64 CIDP patients diagnosed according to the American Academy of Neurology criteria [78] (see section 4) and plasma OPN levels has been evaluated in 44 CIDP patients of the previously group and 22 healthy controls, which samples have been obtained from the transfusion services of the Neurology Departments of University of the Eastern Piedmont 'Amedeo Avogadro' Novara. Patients and controls are unrelated, Caucasian and Italian, matched for age and gender and analysed in parallel.

##### 4.2.2 Sample preparations

Genomic DNA samples of each subject enrolled in the study have been isolated from peripheral blood using standard methods. Plasma samples have been obtained after centrifugation and stored at -80°C for measurements of cytokine levels.

#### 4.2.3 DNA analysis

From genomic samples, the +1239A>C SNP of OPN gene has been typed as previously reported (article 2).

#### 4.2.3 OPN ELISA assay

Plasma OPN concentration has been evaluate in a capture enzyme-linked immunoadsorbent assay (ELISA) according to the protocol provided by the manufacturer (IBL, Gunma, Japan). All assays have been performed in duplicate. The optical density has been measured at 450 nm with a microplate reader (Bio-Rad, Hercules, CA, USA).

#### 4.2.4 Statistical analysis

ELISA data comparisons have been performed with the nonparametric Mann-Whitney U-test. The  $p$  value is two-tailed and the significance cut-off is  $p < 0,05$ .

### 4.3 Preliminary results and conclusions

#### 4.3.1 CIDP patients display increased OPN plasma levels

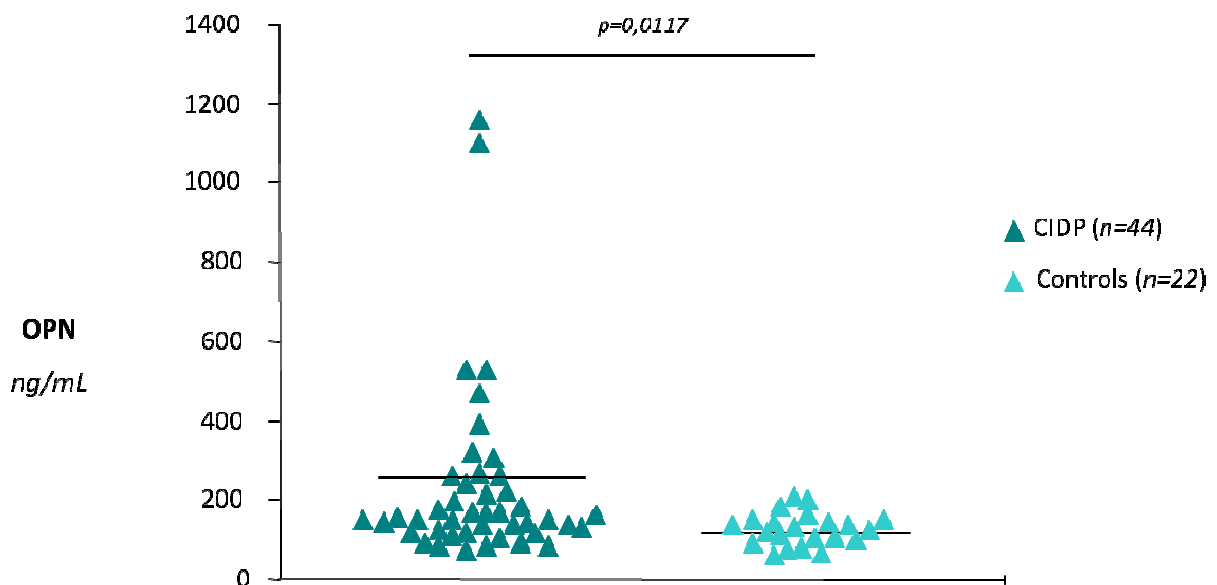

**Figure 4.1:** OPN concentration in plasma samples from 44 CIDP patients and 22 age-matched healthy controls. Lines indicate the median values for each group (CIDP patients: 233,5 ng/mL; controls:129,6 ng/mL). The  $p$  value has been calculated using the Mann-Whitney U test.

OPN concentration has been evaluated performing an ELISA assay on plasma samples from 44 CIDP patients and 22 age-matched controls. Results show that OPN plasma levels are significantly

increased in CIDP patients compared to controls (mean value: CIDP patients 233,5 ng/mL vs controls 129,6 ng/mL;  $p=0,011$ ).

#### 4.3.2 Analysis of OPN +1239A>C SNP in CIDP patients

SNP + 1239	
Genotype	CIDP (n=64)
AA	30 (47)
AC	26 (41)
CC	8 (12)
AA	30 (47)
Non-AA	34 (53)

**Table 4.1:** Frequency distribution of OPN +1239A>C genotypes in CIDP patients. Number of subject and proportions are shown in the brackets.

The +1239A>C SNP located on 3' end of OPN gene has been typed also in 64 CIDP patients. The frequency of homozygotes for +1239A allele is similar to those previously reported in MS patients (47% vs 46%) (**article 2**).

These preliminary results suggest that OPN may be involved in CIDP, but further studies are needed to clearly establish the role of OPN in CIDP development. Firstly these findings must be confirmed in a larger sample of patients compared to age-matched controls. In addition, it can be observed if the increased OPN plasma level are due to inflammation that generally occurs in CIDP or to the genetic variations, since it has been demonstrated in several autoimmune diseases including MS [65] that haplotype B or C carriers show higher OPN level than haplotype A carriers. Furthermore, the role of these variations on CIDP evolution may be assess by analysing their frequency in comparison to the clinical courses of the disease.

## LIST OF PUBLICATIONS

- Aricò M, Boggio E, Cetica V, Melensi M, Orilieri E, Clemente N, Cappellano G, **Buttini S**, Soluri MF, Comi C, Dufour C, Pende D, Dianzani I, Ellis SR, Pagliano S, Marcenaro S, Ramenghi U, Chiocchetti A, Dianzani U. **Variations of the UNC13D gene in patients with autoimmune lymphoproliferative syndrome.** Plos One 2013; 8(7): e68045.
- Comi C, Cappellano G, Chiocchetti A, Orilieri E, **Buttini S**, Ghezzi L, Galimberti D, Guerini F, Barizzone N, Perla F, Leone M, D'Alfonso S, Caputo D, Scarpini E, Cantello R, Dianzani U. **The impact of osteopontin gene variations on multiple sclerosis development and progression.** Clin Dev Immunol 2012; 2012: 212893.

## REFERENCES

1. Compston A, Coles A. **Multiple sclerosis**. *Lancet* 2008; 372 (9648): 1502-17. Review.
2. Kingwell E, Marriott JJ, Jetté N, Pringsheim T, Makhani N, Morrow SA, Fisk JD, Evans C, Béland SG, Kulaga S, Dykeman J, Wolfson C, Koch MW, Marrie RA. **Incidence and prevalence of multiple sclerosis in Europe: a systematic review**. *BMC Neurol* 2013; 13: 128.
3. Hauser SL, Oksenberg JR. **The neurobiology of multiple sclerosis: genes, inflammation, and neurodegeneration**. *Neuron* 2006; 52(1): 61-76.
4. Josey L, Curley M, Jafari Mousavi F, Taylor BV, Lucas R, Coulthard A. **Imaging and diagnostic criteria for Multiple Sclerosis: are we there yet?** *J Med Imaging Radiat Oncol* 2012; 56(6): 588-93. Review.
5. Barten LJ, Allington DR, Procacci KA, Rivery MP. **New approaches in the management of multiple sclerosis**. *Drug Design Development and Theraphy* 2010; 4: 343-66. Review.
6. Muñoz-Culla M, Irizar H, Otaegui D. **The genetics of multiple sclerosis: review of current and emerging candidates**. *Appl Clin Genet* 2013; 6: 63-73. Review.
7. Comabella S, Khoury SJ. **Immunopathogenesis of multiple sclerosis**. *Clin Immunol* 2012; 142(1): 2-8. Review.
8. Constantinescu CS, Farooqi N, O'Brien K, Gran B. **Experimental autoimmune encephalomyelitis (EAE) as a model for multiple sclerosis (MS)**. *Br J Pharmacol* 2011; 164(4): 1079-106. Review.
9. Baron JL, Madri JA, Ruddle NH, Hashim G, Janeway CA Jr. **Surface expression of  $\alpha 4$  integrin by CD4 T cells is requisite for their entry into brain parenchima**. *J Exp Med* 1993; 177(1): 57-68.
10. Waubant E, Goodkin DE, Gee L, Bacchetti P, Sloan R, Stewart T, Andersson BP, Stabler G, Miller K. **Serum MMP-9 and TIMP-1 levels are related to MRI activity in relapsing multiple sclerosis**. *Neurology* 1999; 53(7): 1397-401.
11. Tzartos JS, Friese MA, Craner MJ, Palace J, Newcombe J, Esiri MM, Fugger L. **Interleukin-17 production in central nervous system-infiltrating T cells and glial cells is associated with active disease in multiple sclerosis**. *Am J Pathol* 2008; 172(1): 146-55.
12. Brucklacher-Waldert V, Stuermer K, Kolster M, Wolthausen J, Tolosa E. **Phenotypical and functional characterization of T helper 17 cells in multiple sclerosis**. *Brain* 2009; 132(Pt 12): 3329-41.
13. Viglietta V, Baecher-Allan C, Weiner HL, Hafler DA. **Loss of functional suppression by CD4+CD25+ regulatory T cells in patients with multiple sclerosis**. *J Exp Med* 2004; 199(7): 971-9.
14. Dimachkie MM, Barohn RJ. **Chronic inflammatory demyelinating polyneuropathy**. *Curr Treat Options Neurol* 2013; 15(3): 350-66.
15. Chiò A, Cocito D, Bottacchi E, Buffa C, Leone M, Plano F, et al. **Idiopathic chronic inflammatory demyelinating polyneuropathy: an epidemiological study in Italy**. *J Neurol Neurosurg Psychiatry* 2007; 78(12): 1349-53.
16. Vallat JM, Sommer C, Magy L. **Chronic inflammatory demyelinating polyradiculoneuropathy: diagnostic and therapeutic challenges for a treatable condition**. *Lancet Neurol* 2010; 9(4): 402-12. Review.
17. Köller H, Kieseier BC, Jander S, Hartung HP. **Chronic inflammatory demyelinating polyneuropathy**. *N Engl J Med* 2005; 352(13): 1343-56. Review.
18. Stewart GJ, Pollard JD, McLeod JG, Wolnizer CM. **HLA antigens in the Landry-Guillain-Barré syndrome and chronic relapsing polyneuritis**. *Ann Neurol* 1978; 4(3): 285-9.

19. Feeney DJ, Pollard JD, McLeod JG, Stewart GJ, Doran TJ. **HLA antigens in chronic inflammatory demyelinating polyneuropathy.** *J Neurol Neurosurg Psychiatry* 1990; 53(2): 170-2.
20. Vaughan RW, Adam AM, Gray IA, Hughes RA, Sanders EA, van Dam M, Welsh KI. **Major histocompatibility complex class I and class II polymorphism in chronic idiopathic demyelinating polyradiculoneuropathy.** *J Neuroimmunol* 1990; 27(2-3): 149-53.
21. Van Doorn PA, Schreuder GM, Vermeulen M, D'Amaro J, Brand A. **HLA antigens in patients with chronic inflammatory demyelinating polyneuropathy.** *J Neuroimmunol* 1991; 32(2): 133-9.
22. McCombe PA, Csurhes PA, Green JM. **Studies of HLA associations in male and female patients with Guillain-Barré syndrome (GBS) and chronic inflammatory demyelinating polyradiculoneuropathy (CIDP).** *J Neuroimmunol* 2006; 180(1-2): 172-7.
23. Mrad M, Fekih-Mrissa N, Mansour M, Seyah A, Riahi A, Gritli N, Mrissa R. **Association of HLA-DR/DQ polymorphism with chronic inflammatory demyelinating polyradiculoneuropathy (CIDP) in Tunisian patients.** *Transfus Apher Sci* 2013; 49(3): 623-6.
24. Notturmo F, Pace M, De Angelis MV, Caporale CM, Giovannini A, Uncini A. **Susceptibility to chronic inflammatory demyelinating polyradiculoneuropathy is associated to polymorphic GA repeat in the SH2D2A gene.** *J Neuroimmunol* 2008; 197(2): 124-7.
25. Iijima M, Koike H, Katsuno M, Sobue G. **Polymorphism of transient axonal glycoprotein-1 in chronic inflammatory demyelinating polyneuropathy.** *J Peripher Nerv Syst* 2011; 16 Suppl 1: 52-5.
26. Pang SY, Chan KH, Mak WW, Kung MH, Lee CN, Tsoi TH, Yip EK, Ho SL. **Single-nucleotide polymorphism of transient axonal glycoprotein-1 and its correlation with clinical features and prognosis in chronic inflammatory demyelinating polyneuropathy.** *J Peripher Nerv Syst* 2012; 17(1): 72-5.
27. Hughes RA, Allen D, Makowska A, Gregson NA. **Pathogenesis of chronic inflammatory demyelinating polyradiculoneuropathy.** *J Periph Nerv Syst* 2006; 11(1): 30-46. Review.
28. Winer J, Hughes S, Cooper J, Ben-Smith A, Savage C. **Gamma delta T cells infiltrating nerve biopsies from patients with inflammatory neuropathy.** *J Neurol* 2002; 249(5): 616-21.
29. Kanda T, Numata Y, Mizusawa H. **Chronic inflammatory demyelinating polyneuropathy: decreased claudin-5 and relocated ZO-1.** *J Neurol Neurosurg Psychiatry* 2004; 75(5): 765-9.
30. Van Rhijn I, Van den Berg LH, Bosboom WM, Otten HG, Logtenberg T. **Expression of accessory molecules for T-cell activation in peripheral nerve of patients with CIDP and vasculitic neuropathy.** *Brain* 2000; 123(Pt10): 2020-9.
31. Comi C, Gaviani P, Leone M, Ferretti M, Castelli L, Mesturini R, Ubezio G, Chiocchetti A, Osio M, Muscia F, Bogliun G, Corso G, Gavazzi A, Mariani C, Cantello R, Monaco F, Dianzani U. **Fas-mediated T-cell apoptosis is impaired in patients with chronic inflammatory demyelinating polyneuropathy.** *J Peripher Nerv Syst* 2006; 11(1): 53-60.
32. Chi LJ, Wang HB, Wang WZ. **Impairment of circulating CD4+CD25+ regulatory T cells in patients with chronic inflammatory demyelinating polyradiculoneuropathy.** *J Peripher Nerv Syst* 2008; 13(1): 54-63.
33. Kiefer R, Dangond F, Mueller M, Toyka KV, Hafler DA, Hartung HP. **Enhanced B7 costimulatory molecule expression in inflammatory human sural nerve biopsies.** *J Neurol Neurosurg Psychiatry* 2000; 69(3): 362-8.
34. Murata K, Dalakas MC. **Expression of the co-stimulatory molecule BB-1, the ligands CTLA-4 and CD28 and their mRNAs in chronic inflammatory demyelinating polyneuropathy.** *Brain* 2000; 123(Pt8): 1660-6.
35. Salomon B, Rhee L, Bour-Jordan H, et al. **Development of spontaneous autoimmune peripheral polyneuropathy in B7-2-deficient NOD mice.** *J Exp Med* 2001; 194(5): 677-84.

36. Hu W, Janke A, Ortler S, et al. **Expression of CD28-related costimulatory molecule and its ligand in inflammatory neuropathies.** *Neurology* 2007; 68(4): 277-82.
37. Kawasaki T, Oka N, Akiguchi I, Miyamoto K, Kaji R, Shibasaki H. **Up-regulation of cyclooxygenase-2 in inflammatory demyelinating neuropathy.** *Acta Neuropathol* 2001; 101(2): 154-8.
38. Yan WX, Archelos JJ, Hartung HP, Pollard JD. **PO protein is a target antigen in chronic inflammatory demyelinating polyradiculoneuropathy.** *Ann Neurol* 2001; 50(3): 286-92.
39. Kim HJ, Jung CG, Jensen MA, Dukala D, Soliven B. **Targeting of myelin protein zero in a spontaneous autoimmune polyneuropathy.** *J Immunol* 2008; 181(12): 8753-60.
40. Sanvito L, Makowska A, Mahdi-Rogers M, Hadden RH, Peakman M, Gregson N, Nemni R, Hughes RA. **Humoral and cellular immune responses to myelin protein peptides in chronic inflammatory demyelinating polyradiculoneuropathy.** *J Neurol Neurosurg Psychiatry* 2009; 80(3):333-8.
41. Koch H, Hofmann K, Brose N. **Definition of Munc13-homology-domains and characterization of a novel ubiquitously expressed Munc13 isoform.** *Biochem J* 2000; 349(Pt1): 247-53.
42. Feldmann J, Callebaut I, Raposo G, Certain S, Bacq D, Dumont C, Lambert N, Ouachée-Chardin M, Chedeville G, Tamary H, Minard-Colin V, Vilmer E, Blanche S, Le Deist F, Fischer A, de Saint Basile G. **Munc13-4 is essential for cytolytic granules fusion and is mutated in a form of familial hemophagocytic lymphohistiocytosis (FHL3).** *Cell* 2003; 115(4): 461-73.
43. De Saint Basile G, Ménasché G, Fischer A. **Molecular mechanisms of biogenesis and exocytosis of cytotoxic granules.** *Nat Rev Immunol* 2010; 10(8): 568-79. Review.
44. Katano H, Cohen JL. **Perforin and lymphohistiocytic proliferative disorders.** *Br J Haematol* 2005; 128(6): 739-50. Review.
45. Rieux-Laucat F, Le Deist F, Hivroz C, Robert IA, Debatin KM, Fisher A, de Villartay JP. **Mutations in Fas associated with human lymphoproliferative syndrome and autoimmunity.** *Science* 1995; 268(5215): 1347-9.
46. Straus SE, Sneller M, Lenardo MJ, Puck JM, Strober W. **An inherited disorder of lymphocyte apoptosis: the autoimmune lymphoproliferative syndrome.** *Ann Intern Med* 1999; 130(7): 591-601.
47. Oliveira JB, Bleesing JJ, Dianzani U, Fleisher TA, Jaffe ES, Lenardo MJ, Rieux-Laucat F, Siegel RM, Su HC, Teachey DT, Rao VK. **Revised diagnostic criteria and classification for the autoimmune lymphoproliferative syndrome (ALPS): report from the 2009 NIH International Workshop.** *Blood* 2010; 116(14): 35-40.
48. Clementi R, Chiochetti A, Cappellano G, Cerutti E, Ferretti M, Orilieri E, Dianzani I, Ferrarini M, Bregni M, Danesino C, Bozzi V, Putti MC, Cerutti F, Cometa A, Locatelli F, Maccario R, Ramenghi U, Dianzani U. **Variations of the perforin gene in patients with autoimmunità/lymphoproliferation and defective Fas function.** *Blood* 2006; 108(9): 3079-84.
49. Comi C, Leone M, Benisconi S, DeFranco S, Bottarel F, Mezzatesta C, Chiochetti A, Perla F, Monaco F, Dianzani U. **Defective T cell Fas function in patients with multiple sclerosis.** *Neurology* 2000; 55(7): 921-927.
50. Cappellano G, Orilieri E, Comi C, Chiochetti A, Bocca S, Boggio E, Bernardone IS, Cometa A, Clementi R, Barizzone N, D'Alfonso S, Corrado L, Galimberti D, Scarpini E, Guerini FR, Caputo D, Paolicelli D, Trojano M, Figa-Talamanca L, Salvetti M, Perla F, Leone M, Monaco F, Dianzani U. **Variations of the perforin gene in patients with multiple sclerosis.** *Genes Immun* 2008; 9(5): 438-444.
51. Wang KX, Denhardt DT. **Osteopontin: role in immune regulation and stress responses.** *Cytokine Growth Factor Rev* 2008; 19(5-6): 333-45. Review.
52. Ashkar S, Weber GF, Panoutsakopoulou V, Sanchirico ME, Jansson M, Zawaideh S, Rittling SR, Denhardt DT, Glimcher MJ, Cantor H. **Eta-1 (osteopontin): an early component of type-1 (cell-mediated) immunity.** *Science* 2000; 287(5454): 860-4.



53. Mielgo A, van Driel M, Bloem A, Landmann L, Gunthert U. **A novel antiapoptotic mechanism based on interference of Fas signaling by CD44 variant isoforms.** *Cell Death Differ* 2006; 13(3): 465-77.
54. Shinohara ML, Kim HJ, Kim JH, Garcia VA, Cantor H. **Alternative translation of osteopontin generates intracellular and secreted isoforms that mediate distinct biological activities in dendritic cells.** *Proc Natl Acad Sci USA* 2008; 105 (20): 7235-9.
55. Kawamura K, Iyonaga K, Ichiyasu H, Nagano J, Suga M, Sasaki Y. **Differentiation, maturation, and survival of dendritic cells by osteopontin regulation.** *Clin Diagn Lab Immunol* 2005; 12(1): 206-12.
56. Renkl AC, Wussler J, Ahrens T, Thoma K, Kon S, Uede T, Martin SF, Simon JC, Weiss JM. **Osteopontin functionally activates dendritic cells and induces their differentiation toward a Th1-polarizing phenotype.** *Blood* 2005; 106(3): 946-55.
57. Chabas D, Baranzini SE, Mitchell D, Bernard CC, Rittling SR, Denhardt DT, Sobel RA, Lock C, Karpuj M, Pedotti R, Heller R, Oksenberg JR, Steinman L. **The influence of the proinflammatory cytokine, osteopontin, on autoimmune demyelinating disease.** *Science* 2001; 294(5547): 1731-5.
58. Vogt MH, Lopatinskaya L, Smits M, Polman CH, Nagelkerken L. **Elevated osteopontin levels in active relapsing-remitting multiple sclerosis.** *Ann Neurol* 2003; 53(6): 819-22.
59. Comabella M, Pericot I, Goertsches R, Nos C, Castillo M, Blas Navarro J, Rio J, Montalban X. **Plasma osteopontin levels in multiple sclerosis.** *J Neuroimmunol* 2005; 158(1-2): 231-9.
60. Hur EM, Youssef S, Haws ME, Zhang SY, Sobel RA, Steinman L. **Osteopontin-induced relapse and progression of autoimmune brain disease through enhanced survival of activated T cells.** *Nat Immunol* 2007; 8(1): 74-83.
61. Steinman L. **A molecular trio in relapse and remission in multiple sclerosis.** *Nat Rev Immunol* 2009; 9(6): 440-7. Review.
62. Murugaiyan G, Mittal A, Weiner HL. **Increased osteopontin expression in dendritic cells amplifies IL-17 production by CD4+ T cells in experimental autoimmune encephalomyelitis and in multiple sclerosis.** *J Immunol* 2008; 181(11): 7480-8.
63. Chiocchetti, A, Indelicato M, Bensi T, Mesturini R, Giordano M, Sametti S, Castelli L, Bottarel F, Mazzarino MC, Garbarini L, Giacobelli F, Valesini G, Santoro C, Dianzani I, Ramenghi U, Dianzani U. **High levels of Osteopontin associated to polymorphisms in its gene are a risk factor for development of autoimmunity/lymphoproliferation.** *Blood* 2004; 103(4): 1376-82.
64. D'Alfonso S, Barizzone N, Giordano M, Chiocchetti A, Magnani C, Castelli L, Indelicato M, Giacobelli F, Marchini M, Scorza R, Danieli MG, Cappelli M, Migliaresi S, Bigliardo B, Sabbadini MG, Baldissera E, Galeazzi M, Sebastiani GD, Minisola G, Ravazzolo R, Dianzani U, Momigliano-Richiardi P. **Two single-nucleotide polymorphisms in the 5' and 3' ends of the osteopontin gene contribute to susceptibility to systemic lupus erythematosus.** *Arthritis Rheum* 2005; 52(2): 539-47.
65. Chiocchetti A, Comi C, Indelicato M, Castelli L, Mesturini R, Bensi T, Mazzarino MC, Giordano M, D'Alfonso S, Momigliano-Richiardi P, Liguori M, Zorzon M, Amoroso A, Trojano M, Monaco F, Leone M, Magnani C, Dianzani U. **Osteopontin gene haplotypes correlate with multiple sclerosis development and progression.** *J Neuroimmunol* 2005; 163(1-2): 172-8.
66. Chiocchetti A, Orilieri E, Cappellano G, Barizzone N, D'Alfonso S, D'Annunzio G, Lorini R, Ravazzolo R, Cadario F, Martinetti M, Calcaterra V, Cerutti F, Bruno G, Larizza D, Dianzani U. **The osteopontin gene +1239A/C single nucleotide polymorphism is associated with type 1 diabetes mellitus in the Italian population.** *Int J Immunopathol Pharmacol* 2010; 23(1):263-9.
67. Barizzone N, Marchini M, Cappiello F, Chiocchetti A, Orilieri E, Ferrante D, Corrado L, Mellone S, Scorza R, Dianzani U, D'Alfonso S. **Association of osteopontin regulatory polymorphisms with systemic sclerosis.** *Hum Immunol* 2011; 72(10): 930-4.

68. Giacomelli F, Marciano R, Pistorio A et al. **Polymorphisms in the osteopontin promoter affect its transcriptional activity.** *Physiological Genomics* 2005; 20(1): 87-96.
69. Voskoboinik I, Smyth MJ, Trapani JA. **Perforin-mediated target-cell death and immune homeostasis.** *Nat Rev Immunol* 2006; 6(12): 940-52. Review.
70. Voskoboinik I, Thia MC, Fletcher J, Ciccone A, Browne K, Smyth MJ, Trapani JA. **Calcium-dependent plasma membrane binding and cell lysis by perforin are mediated through its C2 domain: A critical role for aspartate residues 429, 435, 483, and 485 but not 491.** *J Biol Chem* 2005; 280(9): 8426-34.
71. Uellner R, Zvelebil MJ, Hopkins J, Jones J, MacDougall LK, Morgan BP, Podack E, Waterfield MD, Griffiths GM. **Perforin is activated by a proteolytic cleavage during biosynthesis which reveals a phospholipid-binding C2 domain.** *EMBO Journal* 1997; 16(24): 7287-96.
72. Voskoboinik I, Dunstone MA, Barran K, Whisstock JC, Trapani JA. **Perforin: structure, function, and role in human immunopathology.** *Immunol Rev* 2010; 235(1): 35-54. Review.
73. Orilieri E, Cappellano G, Clementi R, Cometa A, Ferretti M, Cerutti E, Cadario F, Martinetti M, Larizza D, Calcaterra V, D'Annunzio G, Lorini R, Cerutti F, Bruno G, Chiocchetti A, Dianzani U. **Variations of the perforin gene in patients with type 1 diabetes.** *Diabetes* 2008; 57(4): 1078-83.
74. Bonetti B, Valdo P, Ossi G, De Toni L, Massotto B, Marconi S, Rizzuto N, Nardelli E, Moretto G. **T-cell cytotoxicity of human Schwann cells: TNFalpha promotes fasL-mediated apoptosis and IFNgamma perforin-mediated lysis.** *Glia* 2003; 43(2): 141-8.
75. Comi C, Osio M, Ferretti M, Mesturini R, Cappellano G, Chiocchetti A, Carecchio M, Nascimbene C, Varrasi C, Cantello R, Mariani C, Monaco F, Dianzani U. **Defective Fas-mediated T-cell apoptosis predicts acute onset CIDP.** *J Peripher Nerv Syst* 2009; 14(2): 101-6.
76. Comi C. **Fas-mediated T-cell apoptosis in chronic inflammatory demyelinating polyneuropathy.** *J Peripher Nerv Syst* 2011; 16 Suppl 1: 45-7.
77. Comi C, Fleetwood T, Dianzani U. **The role of T cell apoptosis in nervous system autoimmunity.** *Autoimmun Rev* 2012; 12(2): 150-6. Review.
78. Ad Hoc Subcommittee of the American Academy of Neurology AIDS Task Force. **Research criteria for diagnosis of chronic inflammatory demyelinating polyneuropathy (CIDP).** *Neurology* 1991; 41(5): 617-8. Review.
79. Solomou EE, Gibellini F, Stewart B, Malide D, Berg M, Visconte V, Green S, Childs R, Chanock SJ, Young NS. **Perforin gene mutations in patients with acquired aplastic anemia.** *Blood* 2007; 109(12): 5234-7.
80. Ding Q, Yang L. **Perforin gene mutations in 77 Chinese patients with lymphomas.** *World J Emerg Med* 2013; 4(2): 128-32.
81. Voskoboinik I, Thia MC, Trapani JA. **A functional analysis of the putative polymorphisms A91V and N252S and 22 missense perforin mutations associated with familial hemophagocytic lymphohistiocytosis.** *Blood* 2005; 105(12): 4700-6.
82. Trambas C, Gallo F, Pende D, Marcenaro S, Moretta L, De Fusco C, Santoro A, Notarangelo L, Arico M, Griffiths GM. **A single amino acid change, A91V, leads to conformational changes that can impair processing to the active form of perforin.** *Blood* 2005; 106(3):932-7.
83. Risma KA, Frayer RW, Filipovich AH, Sumegi J. **Aberrant maturation of mutant perforin underlies the clinical diversity of hemophagocytic lymphohistiocytosis.** *J Clin Invest* 2006; 116(1): 182-92.
84. Voskoboinik I, Sutton VR, Ciccone A, House CM, Chia J, Darcy PK et al. **Perforin activity and immune homeostasis: the common A91V polymorphism in perforin results in both pre- and post-synaptic defects in function.** *Blood* 2007; 110(4): 1184-90.

85. Ahn M, Lee Y, Moon C, Jin JK, Matsumoto Y, Koh CS, Kim HM, Shin T. **Upregulation of osteopontin in Schwann cells of the sciatic nerves of Lewis rats with experimental autoimmune neuritis.** Neuroscience Letters 2004; 372(1-2): 137-41.
86. Chi LJ, XU WH, Zhang ZW, Huang HT, Zhang LM, Zhou J. **Distribution of Th17 cells and Th1 cells in peripheral blood and cerebrospinal fluid in chronic inflammatory demyelinating polyradiculoneuropathy.** J Peripher Nerv Syst 2010; 15(4): 345-56.

## ABBREVIATIONS

### A

**AIDS:** acquired immune deficiency syndrome.  
**ALPS:** autoimmune lymphoproliferative syndrome  
**APCs:** antigen presenting cells.

### B

**BBB:** blood-brain barrier.  
**BNB:** blood-nerve barrier.

### C

**CASP-10:** caspase-10.  
**CD4:** cluster of differentiation 4.  
**CD80:** cluster of differentiation 80 (B7-1).  
**CD86:** cluster of differentiation 86 (B7-2).  
**CI:** confidence intervals.  
**CIDP:** chronic inflammatory demyelinating polyneuropathy.  
**CNS:** central nervous systems.  
**CSF:** cerebrospinal fluid.  
**CTLs:** cytotoxic T lymphocytes.

### D

**DALD:** Diansani lymphoproliferative disease  
**DCs:** dendritic cells.  
**DN:** double negative.

### E

**EAE:** experimental autoimmune encephalomyelitis.  
**EAN:** experimental autoimmune neuritis.  
**EGF:** epidermal growth factor.  
**ELISA:** enzyme linked immunosorbent assay.  
**Eta-1:** early T cell activation (OPN).

### F

**Fas:** Fas cell surface death receptor (APO-1, apoptosis antigen 1; CD95).  
**FasL:** Fas ligand.  
**FHL:** familial haemophagocytic lymphohistiocytosis.  
**FOXO3A:** forkhead box O3A.

### G

**GBS:** Guillain-Barré syndrome.  
**GWAS:** Genome-Wide Association Studies.

### H

**HLA:** human leukocyte antigen.

### I

**ICOS:** inducible T cell co-stimulator.  
**ICOS-L:** inducible T cell co-stimulator ligand.  
**IFNs:** interferons.  
**IFN $\gamma$ :** interferon- $\gamma$ .  
**IgG:** immunoglobulin .  
**IL-17:** interleukin-17.  
**IL-2:** interleukin-2.

**IVIGs:** intravenous immunoglobulins.

### M

**MAC:** membrane-attack complex.  
**MBP:** myelin basic protein.  
**MGUS:** monoclonal gammopathy of undetermined significance.  
**MHC:** major histocompatibility complex.  
**MHDs:** Munc13 homology domains.  
**miRNAs:** micro-RNAs.  
**MMPs:** matrix metalloproteinases.  
**MOG:** myelin oligodendrocyte glycoprotein.  
**MRI:** magnetic resonance imaging.  
**MS:** multiple sclerosis.  
**Munc13-4:** protein unc-13 homolog D (C. Elegans).

### N

**NF-KB:** nuclear factor-KB.  
**NK:** natural killer.  
**NOD:** non-obese diabetic.

### O

**OPN:** osteopontin.  
**OR:** odds ratio.

### P

**P0:** myelin protein zero.  
**P2:** myelin protein.  
**PAD2:** peptidyl arginine deaminase type II.  
**PBMCs:** peripheral blood mononuclear cells.  
**PCR:** polymerase chain reaction.  
**PLP:** proteolipid protein.  
**PMP22:** peripheral myelin protein 22.  
**PNS:** peripheral nervous system.  
**PP:** primary progressive.  
**PPMS:** primary progressive multiple sclerosis.  
**PRF1:** perforin gene.  
**PRMS:** progressive relapsing multiple sclerosis.

### R

**Rab7:** Ras related protein 7.  
**RRMS:** relapsing-remitting multiple sclerosis.

### S

**S1PR:** sphingosine-1-phosphate receptor.  
**SH2D2:** SH2 domain containing 2A, T-cell-specific adapter protein (TSAD) gene.  
**SLE:** systemic lupus erythematosus.  
**SLP2:** synaptotagmin-like protein.  
**SNARE:** N-ethylmaleimide-sensitive factor attachment protein receptor.  
**SNPs:** single nucleotide polymorphisms.  
**SP:** secondary progressive.  
**SPMS:** secondary progressive multiple sclerosis.

**SPP1:** secreted phosphoprotein 1 (*OPN* gene).

**STAT3:** signal transducer and activator of transcription 3.

**STX11:** syntaxin-11 gene.

**STXBP2:** syntaxin-binding protein 2 (*Munc18-2* gene).

#### T

**TAG-1:** transient axonal glycoprotein-1.

**Th1:** lymphocyte T helper type 1.

**Th17:** lymphocyte T helper type 17.

**TNF- $\alpha$ :** tumor necrosis factor- $\alpha$ .

**Tregs:** regulatory T cells.

**TYK2:** Tyrosine Kinase 2.

**t-SNARE:** target SNARE

#### U

**UNC13D:** *unc-13* homolog D (*C. Elegans*).

**UTR:** untranslated region.

#### V

**VCAM-1:** vascular cell adhesion molecule 1.

**VLA-4:** very late activation antigen 4.

**v-SNARE:** vesicle SNARE.

#### W

**wt:** wild type.

#### Z

**ZO-1:** zona occludens protein

## **ACKNOWLEDGEMENTS**

*"...surprises, like misfortunes, seldom come alone"  
from The Adventure of Oliver Twist, Charles Dickens*

Thanks to...

*my husband Stefano,  
this is for us and for our dreams becoming true.*

*Cris,  
who gives me this great opportunity.*

*Beppe,  
for your honesty and the continuous support. You are so brilliant!*

*Valentina and Valeria,  
for your friendship and the good times enjoyed together.*

*my mom Massimiliana and my dad Domenico,  
and all those who always believed in me (Laura, Maurizio, Cesare and Valeria).*

*Brian, Nick, Aj, Kevin and Howie,  
that with our music always inspire me.*

*"...le sorprese, come le disgrazie, non vengono mai sole"  
da Le avventure di Oliver Twist, Charles Dickens*

Grazie a...

*mio marito Stefano,  
a noi e alla realizzazione dei nostri sogni.*

*Cris  
per avermi dato questa grande opportunità.*

*Beppe,  
per la tua lealtà e il continuo supporto. Sei geniale!*

*Valentina e Valeria,  
per la vostra amicizia e per le belle giornate trascorse insieme.*

*mia mamma Massimiliana e mio papà Domenico,  
e tutti quelli che hanno sempre creduto in me (Laura, Maurizio, Cesare e Valeria).*

*Brian, Nick, AJ, Kevin and Howie,  
che con la loro musica ispirano sempre le mie creazioni.*